

SARASIN-RSBD

Excellent
Engineering
Solutions

Safety Relief Valves

Starflow

WEIR



Introducing Weir

Weir provides critical service and safety valves, specialist pumps and service support to flow control and rotating equipment. Our world-wide reputation is based on engineering excellence applied to a comprehensive range of specialist products and effective customer support.

We have the capability to deliver complete valve solutions for major projects in the power generation, oil and gas exploration and general industrial sectors. Our global network of service operations specialise in the maintenance, upgrade and management of power and industrial assets at customer sites.

Quality assurance

Weir operates quality programmes to cover the full scope of their activities. Comprehensive quality systems have been developed to serve the power, oil and gas and industrial markets which they serve.

The company holds approvals to or complies with:

- ASME Section III 'N', 'NPT', 'NV'
- ASME Section I 'V'
- ASME Section VIII 'UV'
- EN ISO 9001: 2008
- EN ISO 14001: 2004
- OHSAS 18001: 2007
- API Q1 TO API LICENCES API 6D (6D-0182) AND API 6A (6A-0445)
- API STD 520
- API STD 526
- API STD 527
- API STD 2000
- ISO 4126



The Quality systems have been approved for the supply of products to meet the requirements of the Pressure Equipment Directive (PED) and compliance modules A, D1, H, B&D have been applied in categories I through IV respectively.

The company is committed to compliance with legislation and has an established environment and health and safety policy.

An ongoing commitment to customer care is met through the process of continuous improvement and the further development of our systems and processes towards meeting ISO 9001:2008.

Material testing service available

- Non-destructive examination by radiography, ultrasonics, magnetic particle and liquid penetrant.
- Chemical analysis by computer controlled direct reading emission spectrometer.
- Mechanical testing for tensile properties at ambient and elevated temperatures, bend and hardness testing. Charpy testing at ambient, elevated and sub-zero temperatures.

Valve testing facilities

All pressure containing items are hydrostatically tested, seat leakage tested and functionally tested. In addition, gas, packing emission, cryogenic and advanced functional testing can be arranged.



Further technical information can be obtained from our Web site: <http://www.weirpowerindustrial.com>



Weir Power & Industrial France

SARASIN-RSBD

Weir manufactures the Sarasin-RSBD range of pressure safety valves and safety devices for oil and gas, petrochemical and chemical industries, pipelines, thermal and nuclear power plants, sugar refineries and pulp mills.



Machining facility



Steam test facility

The Sarasin-RSBD range of products is manufactured in accordance with ASME, API and ISO standards and therefore can meet most of worldwide customers requirements. The company holds approvals or complies with:

EN ISO 9001:2008 - EN ISO 14001:2004

OHSAS 18001: 2007

PED 97/23/EC Module B+D Category IV

ATEX 94/9/EC

ASME Section I 'V' - ASME Section VIII 'UV'

API STD 520 - API STD 526 - API STD 527

API STD 2000

ISO 4126

SELO

Specifically, Weir can design and manufacture special valves to meet special customer requirements.

CONTENTS

Starflow Introduction	4-5
Description	6-7
Design Information	8-12
Materials and Construction	12-21
Standard Options	22
Selection Tables	23-53
Capacity Tables	54-60
Model Number System	61
How to choose a Starflow valve	62
Applications	63

Introduction

This catalogue describes STARFLOW safety relief valves manufactured for use in refineries, petrochemical and chemical processes, piping, pressure vessels, heat exchangers, cryogenic plants, process steam, thermal relief, compression stations and pipelines.

STARFLOW safety relief valves are designed and manufactured in accordance with API Std 526 and ASME Section VIII Division 1, and have been capacity tested and certified by the National Board of Pressure Vessel Inspectors. The Starflow also meets the requirements of ISO 4126 Part 1.

General STARFLOW High Performance Features

High capacity and performances

STARFLOW safety relief valves are designed on concepts of safety, high performance, interchangeability and simplicity.

These considerations led to the STARFLOW line of valves, P3 (conventional), P4 (balanced bellows), P5 (steam service).

STARFLOW valves are designed to meet the requirements of the ASME Code, Section VIII Div.1 and capacities have been certified with a high discharge coefficient.

STARFLOW safety relief valves are suitable for air, gas or steam service as well as for liquids.

Designed for trouble free operation

The STARFLOW line has been designed to API Std 526 standard with an integral stainless steel nozzle, a self-aligning top-guided disc and disc holder and a single nozzle adjusting ring for blowdown setting. All sliding surfaces are made of stainless steel from different grades providing sufficient difference of hardness to prevent seizing or galling and to increase precision.

The disc is designed to withstand high and low temperatures without leakage due to non-uniform thermal expansion. Its thickness is minimal, and it is self-aligning.

STARFLOW valves, in the "STARSOFT" version, are provided with a soft seat, made of materials such as fluorocarbon, nitrile or silicone for applications where premium tightness is required. The soft seat is designed so that it cannot blow out under pressure.

Full lift within 10% overpressure and short blowdown are achieved with the single adjustable nozzle ring design. The deflector provides a raising force to open the valve completely to permit full

capacity flow. The form of the secondary orifice situated between the deflector and the adjusting ring can be modified to obtain the desired blowdown.

The single nozzle adjusting ring facilitates the setting of the valve. The design of this ring is such that it cannot affect the flow of the valve.

A complete range of safety relief valves

The STARFLOW line includes all orifices from D to T (Complying with API Std 526), plus two extra-large orifices V and W (Complying with ASME B&PVC Section VIII Div.1) and covers the range of 150 lbs to 2500 lbs flange ratings, from 1" (DN 25) to 12" (DN 300). The bodies and bonnets are made from castings, while corrosion resistant materials are used for the internal trim.

Materials are designed for service temperatures from -270°C to 538°C. Different bills of materials have been established to cover most of the possible applications, especially when corrosion is a consideration. Special alloys such as Duplex, Alloy 400 (Monel), Alloy C276, or other materials suitable for sour environments may be supplied on request.

Designed for interchangeability

When starting up or maintaining a process plant, it is sometimes necessary to make modifications to the initial design and change valve configurations.

When the STARFLOW line was designed, it was decided that the different versions of the basic valve were to be interchangeable.

Consequently it is possible to convert any STARFLOW design into another one with the minimum of additional parts.

A conventional type (P3) may very easily be converted into a balanced bellows type (P4) just by adding a bellows sub-assembly.

To reduce inventory, steam valves (P5) use the same components as process valves (P3).

Metal to metal seat tightness and simple operation

The STARFLOW metal-to-metal seated valves are carefully lapped and mirror-polished and lapping is controlled with optical flats. This lapping together with the disc design assures excellent tightness and easy maintenance.

Balanced type
P4

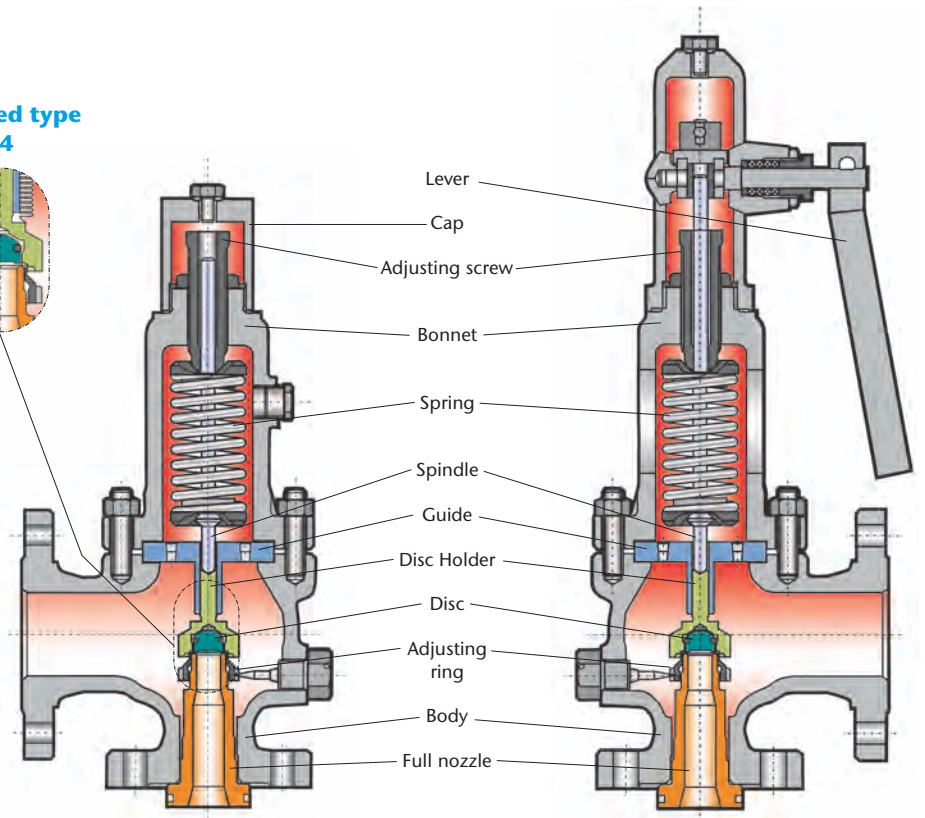
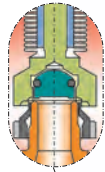

Conventional type P3

Steam type P5

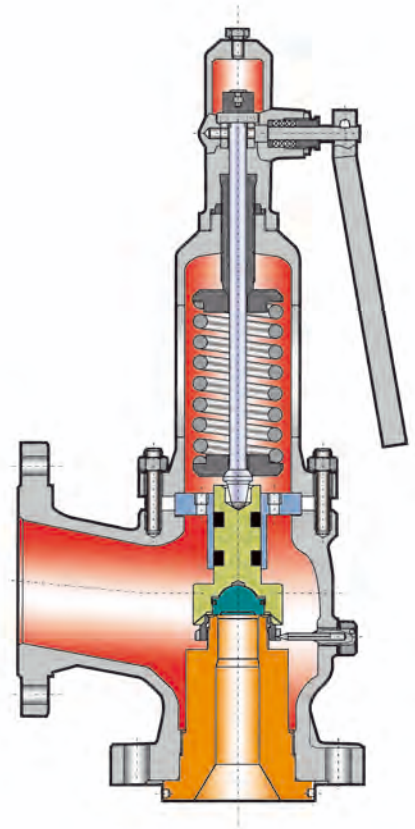

Steam type S5



Description

STARFLOW RANGE

- Certified ASME Section VIII Div. 1 (stamp UV)
- Sizes: 1" x 2" to 12" x 12" x 12" (dual outlet)
- API STD 526 orifices from D to T
- Effective orifice areas from D (0.865 cm²) to W (452 cm²)

STARFLOW P3

- Pressure (API STD 526) from 0.35 to 414 barg
- Pressure (ASME B16.34) from 0.35 to 430 barg
- Temperature from -196°C to +538°C
- "Starsoft" soft seat available for improved tightness

STARFLOW P4

- Ditto as P3
- The balanced bellows isolate spring chamber from media and balance the valve against the back pressure effects.

STARFLOW P5

- Pressure class 150# and 300#
- Pressure (ASME) from 0.35 barg to 45.9 barg
- Temperature upto +538°C
- Stellite nozzle
- Opened bonnet (small orifices) and yoke (large orifices)

STARFLOW S5

- Pressure class 150# to 2500#
- Pressure from 0.35 barg
- Temperature upto 538°C (and over on request)
- Stellite nozzle
- Opened bonnet (small orifices) and yoke (large orifices)
- Enlarged guide (intrinsically balanced)
- Thermoglide rings contact between the guide and the disc holder : improved gliding, no seize, perfect repeatability and smooth opening.

Table 1

STARFLOW P3/P4/P5/S5 Inlet x Outlet Size Combinations (in.) Orifice Area (sq. in)					Inlet Flange Rating ASME B16.5	Outlet Flange Rating ASME B16.5
Actual	0.134	0.273	0.373	0.589		
API	0.110	0.196	0.307	0.503		
ORIFICE	D	E	F	G		
	1 x 2	1 x 2	1 ½ x 2	1 ½ x 3	150	150
	1 x 2	1 x 2	1 ½ x 2	1 ½ x 3	300	
	1 x 2	1 x 2	1 ½ x 2	1 ½ x 3	300	
	1 x 2	1 x 2	1 ½ x 2	1 ½ x 3	600	
	1 ½ x 2	1 ½ x 2	1 ½ x 3	1 ½ x 3	900	300
	1 ½ x 2	1 ½ x 2	1 ½ x 3	2 x 3	1500	
	1 ½ x 3	1 ½ x 3	1 ½ x 3	2 x 3	2500	

Table 2

STARFLOW P3/P4/P5/S5 Inlet x Outlet Size Combinations (in.) Orifice Area (sq. in)													Inlet Flange Rating ASME B16.5	Outlet Flange Rating ASME B16.5
Actual	0.881	1.457	2.097	3.284	4.093	4.987	7.215	12.91	17.81	28.87	46.75	70.10		
API	0.785	1.287	1.838	2.853	3.6	4.34	6.38	11.05	16	26	N/A	N/A		
ORIFICE	H	J	K	L	M	N	P	Q	R	T	V	W		
	1 ½ x 3	2 x 3	3 x 4	3 x 4	4 x 6	4 x 6	4 x 6	6 x 8	6 x 8	8 x 10	10 x 14	12x12x12	150	150
	1 ½ x 3	2 x 3	3 x 4	3 x 4	4 x 6	4 x 6	4 x 6	6 x 8	6 x 8	8 x 10	10 x 14	12x12x12	300	
	2 x 3	3 x 4	3 x 4	4 x 6	4 x 6	4 x 6	4 x 6	6 x 8	6 x 10	8 x 10	10 x 14	12x12x12	300	
	2 x 3	3 x 4	3 x 4	4 x 6	4 x 6	4 x 6	4 x 6	6 x 8	6 x 10	-	-	-	600	
	2 x 3	3 x 4	3 x 6	4 x 6	4 x 6	4 x 6	4 x 6	-	-	-	-	-	900	300
	2 x 3	3 x 4	3 x 6	4 x 6*	-	-	-	-	-	-	-	-	1500	
	-	-	-	-	-	-	-	-	-	-	-	-	2500	

Note: Inlet and outlet size combinations as well as Orifice sizes shown in the table above are compliant with API standard 526 – Fourth Edition, 1995 (and later).
* Supplied with a 150# outlet

Design Information

Set pressure limits and tolerances

Safety relief valves having a set pressure above 1 barg are covered by the requirements of ASME B&PV Code Section VIII Div.1:

- Capacity rated at 10% overpressure in critical discharge conditions, or 0.2 barg, whichever is greater.
- Adjustable blowdown between 5 to 7% of set pressure on compressible fluid.
- Set pressure tolerances :
 - ± 0.13 bar for pressures up to 4.8 bar.
 - ± 3% of set pressure for pressures above 4.8 bar.
- Seat tightness test performed at :
 - 90% of set pressure for pressures above 3.45 bar.
 - 0.35 bar below set pressure for pressures below 3.45 bar.

Flange tolerances and dimensions

STARFLOW safety relief valve flanges are machined to ASME B 16.5 (identical to EN 1759 flanges) except that the raised face dimension of the inlet flange is larger than ASME due to the full nozzle construction.

Centre to face dimensions comply with API Std 526. Flanges may be machined to various facings : raised face - large or small male or female face - large or small tongue or groove face - ring joint face, as well as to various finishes : spiral or concentric serrated, smooth finish, etc. Raised face with smooth finish (Ra 3.2 - 6.3 mm max) is standard.

Any other flange standard is available if specified (EN 1092, DIN 2501).

Set pressure adjustment

Back pressure correction

Type P4 balanced bellows valves do not need any back pressure setting correction. Type P3 conventional valves operating against a constant back pressure are set without back pressure. The spring setting pressure (without back pressure) will then be the actual set pressure derated by the value of the constant back pressure.

Set pressure modifications

The spring should not be re-set for any pressure higher than 5% above or below that for which the safety relief valve is marked (Code ASME Section VIII Div.1, UG126).

Springs

A number is stamped on each valve spring where the size of the wire permits it. The spring number is also stamped on the nameplate. For proper operation and to assure correct alignment of parts, springs should be ordered complete with washers.

If the valve set pressure is to be changed, a new spring may be necessary and the following information should be given :

- 1 • Serial number or nominal valve size and type
- 2 • Set pressure and backpressure
- 3 • Fluid
- 4 • Maximum operating temperature

Working pressure and set pressure

It is recommended to set the safety relief valves as high as possible above the maximum operating pressure.

The margin between the operating pressure and the set pressure should not fall below 10% of the set pressure in order to avoid undesired relief cycles or seat leakage.

For operating pressure very close to set pressure, it is advisable to use pilot operated valves.

Seat tightness of safety relief valves

All STARFLOW safety relief valves are individually tested according to API STD 527 and sealed prior to shipment.

Test procedure

The valve is mounted vertically as indicated in the diagram below. Immediately after triggering, the pressure is maintained at 90% of set pressure or at set pressure less 0.35 barg for valves at less than 3.45 barg. Test pressure is applied for a minimum of 1 minute for valves of inlet sizes up to 2", 2 minutes for sizes 2 1/2", 3" and 4", 5 minutes for sizes 6" and above.

Tightness on air test bench

Air at atmospheric temperature is used as pressure medium. The leakage rate in bubbles per minute shall not exceed the numbers listed in Table 3 for metal/metal seated valves.

For soft seated valves, no leakage is authorized.

For steam valves tested on an air bench, the outlet flange is sealed and the body is filled with water up to 12.7 mm above the nozzle seat. Leakage criteria is equal to half that shown in Table 3.

Tightness on liquid test bench

Water at atmospheric temperature is used as pressure medium. Leakage rate must be less than 0.39 cm³/hr/mm of inlet orifice for metal/metal seated valves. For soft seated valves, no leakage is authorized.

Tightness on steam test bench

No visible or audible leakage is authorized.

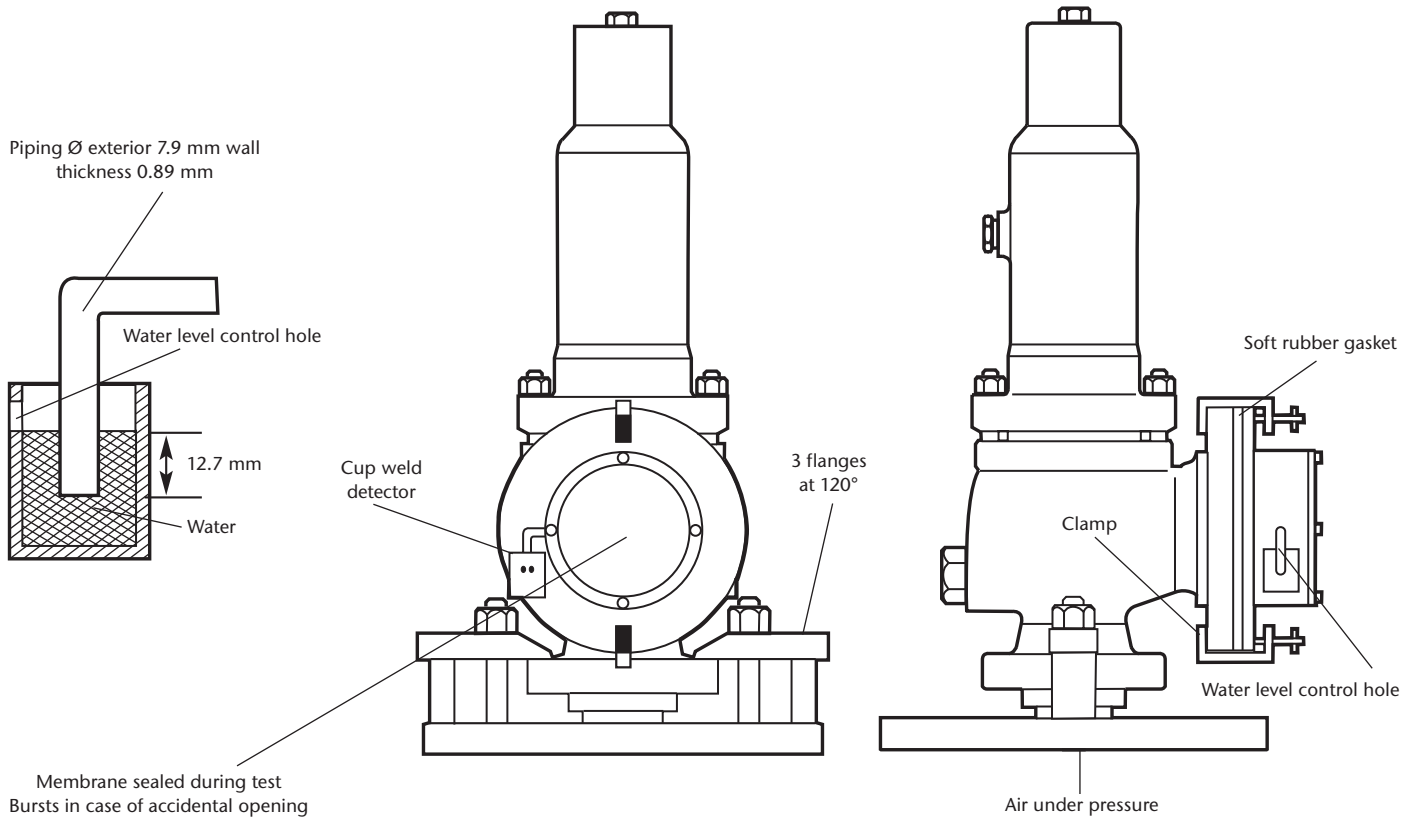

Table 3

Barg	Set pressure		Orifices less than or equal to F			Orifices larger than F		
	Psig	Mpag	Bubbles/minute	Sm ³ /day	SCF/day	Bubbles/minute	Sm ³ /day	SCF/day
1.03-68.96	15-1000	0.103-6.896	40	0.017	0.60	20	0.0085	0.30
103	1500	10.3	60	0.026	0.90	30	0.013	0.45
130	2000	13.0	80	0.034	1.20	40	0.017	0.60
172	2500	17.2	100	0.043	1.50	50	0.021	0.75
207	3000	20.7	100	0.043	1.50	60	0.026	0.90
276	4000	27.6	100	0.043	1.50	80	0.034	1.20
385	5000	38.5	100	0.043	1.50	100	0.043	1.50
414	6000	41.4	100	0.043	1.50	100	0.043	1.50

Storage

Safety relief valves are often stored at the site for many months before they are actually installed.

Unless they are properly stored and protected their performance may be adversely affected. The valves should therefore be left in their shipping boxes, in a vertical position and stored in a dry place until their installation.

Installation

To avoid damage to valves at start up, piping connections, valve inlet and pressure bearing parts should be thoroughly cleaned and all foreign bodies should be eliminated.

Inlet piping

The inside pipe diameter should be equal or superior to the inlet valve diameter. A valve should never be installed on a fitting with a smaller inside diameter than the inlet connection. The connection piping should be as short as possible.

The valve should be mounted vertically on the pipe inlet. The inlet flange bolts and studs should be drawn down evenly and in such a way as to avoid straining the valve body with possible distortion of the nozzle flange or misalignment of the valve parts. Compliance with the above recommendations will assure proper valve operation.

Outlet piping

The outlet piping should be simple and direct, at least of the same diameter as the outlet and designed to minimize loads on the valve:

- Valve discharge loads
- Discharge pipe expansion loads
- Vibrations
- Discharge pipe misalignment causing static loads

Reaction force calculation

The discharge of a pressure relief valve imposes a reactive load which is supported by the piping system. In some cases all reactive loading due to the operation of the valve is transmitted to the valve and inlet piping.

The horizontal reaction force at the outlet of the valve discharging to atmosphere may be evaluated by an approximation formula as follows :

$$F = K_F \times A \times P_1$$

A more precise calculation is provided with the valve data sheet.

Where :

F = is the reactive force in daN

K_F = is a factor which depends on the fluid and the size of the outlet of the valve, as shown hereunder.

A = is the orifice area of the valve nozzle, in cm², to be found in the sizing section of this catalogue.

P₁ = is the absolute relieving pressure, including overpressure, in bar abs.

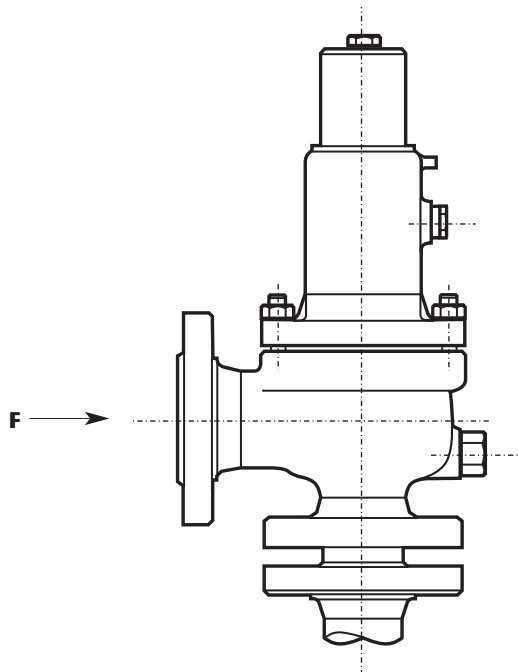

This formula includes both momentum and static pressure effects.

Outlet DN	VALUES OF K _F	
	Fluid : air	Fluid : steam
2" and 2 1/2"	1.9	2.0
3" and 4"	1.5	1.6
6"	1.3	1.3
8" and over	1.1	1.1

Example : For a valve of " T " orifice, outlet DN 10", set at 12.1 bar, operating on air with 10% overpressure :

K_F = 1.1

A = 168cm²

P₁ = (1.10 x 12.1 + 1.013) = 14.32 bar abs

F = 2647 daN

Balanced bellows safety relief valves

Balanced bellows valves should be used :

- When a double tightness barrier is required by the process fluid in the secondary pressure zone of the safety relief valve.
- When the valve is subjected to a back pressure between 10 and 50% of the set pressure.

When a conventional safety relief valve discharges against a back pressure, the opening pressure is the set pressure with atmospheric back pressure augmented by the actual superimposed back pressure just before the valve opens.

If the back pressure is variable, then the opening pressure of a conventional valve will also be variable.

To solve this problem it is highly recommended to use a balanced bellows safety relief valve. The effective area of the bellows is substantially the same as the seating area of the disc on the nozzle and the bellows is vented to atmosphere through a hole drilled into the bonnet wall. The opening pressure of the safety relief valve is then independent of the back pressure.

Back pressure limits for "P4" balanced bellows safety relief valves are shown in the appropriate section of this catalogue.

The design of the STARFLOW safety relief valve is such that a conventional "P3" valve can easily be converted into a balanced bellows "P4" valve just by adding a bellows (part n°19) and removing the vent plug in the bonnet.

Bellows valves type "P4" are available for orifices D to W.

Balanced bellows valves at low set pressure (i.e. below 1.5 barg) should be avoided in small orifices.

Soft seated valves

A soft seated STARFLOW safety relief valve is available for special applications where premium tightness is required or where the operating pressure is very close to the set pressure of the safety relief valve.

The STARSOFT seat design is unique : an elastomer seat is moulded into a groove machined in the valve disc. This design prevents soft seat blowout under the effect of pressure. Metal seat is provided on the external seating area.

With this configuration, the recognised maximum set pressure is 100 barg. For pressures above this value it is possible to use the soft ring design (see cryogenic material on page 14) limited to 200 barg.

A wide variety of soft materials is available for various mediums and temperature ranges. Fluorocarbon is the standard material, suitable for major applications between -18 and +200°C. Silicone, Buna-N (nitrile), Ethylene-Propylene or other materials are available on another design. Other materials, such as resins, are available with another design (see cryogenic materials on page 14).

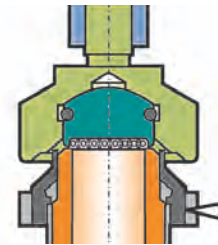

The STARSOFT soft seated valve is bubble tight at 90% of set pressure and meets API STD 527 tightness standard at 95% of the set pressure. Nevertheless it is not recommended to get the operating pressure higher than 93% of the set pressure as per API and ASME requirements. The operating pressure has to be lower than the blowdown (-7% to set pressure).

The compatibility of the fluid with the elastomer should be carefully considered by the purchaser. Full information about the various elastomers to be used on Starsoft is available from the factory.

	Fluorocarbon (Dipolymer)	Silicone
Min. T°	-18°C	-60°C
Max. T°	+200°C	+200°C
Compatible fluids (on Starsoft)	Air Carbon Dioxide Chlorine Water Crude Oil (<121 °C) Detergent Solutions Fuel Oil Gasoline HC Gas Helium Natural Gas Phosphoric Acid Propane Sulfur Chloride (aqu.) Sulfuric Acid (<60%) Sulfuric Acid (100%) Water	Air Ammonia Gas Detergent Solutions Liquid Oxygen Natural Gas Water

Rupture discs and safety valves combination

A rupture disc can be installed upstream of a safety relief valve either as protection against highly corrosive fluid or in order to guarantee complete tightness.

This assembly requires the following arrangements :

- A fragmenting type disc must not be used
- The disc must burst cleanly and leave no obstruction for the fluid once it is broken
- The dimensions of the disc must not be inferior to the inlet DN of the valve
- It must be possible to monitor the space between the rupture disc and the disc of the safety valve all the time and this space must be linked to the atmosphere for as long as the disc has not burst, by means of an excess flow valve. It may also be equipped with a vent valve and a pressure gauge.
- For installation governed by the ASME Code, the combination must be flow tested, and the assigned derating factor applied, or, alternatively for non tested combinations a 0.9 derating factor must be applied.

A rupture disc can also be mounted at the outlet of a safety relief valve.

Materials and Construction

Comparison of various materials

ASME or ASTM designations of material will prevail in this catalogue

This table shows the basic specification of the various materials as well as the corresponding grade in european standards.

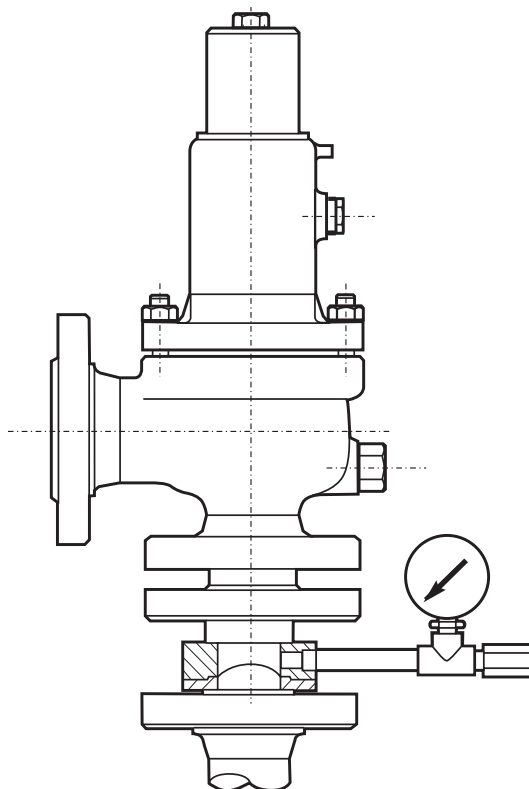
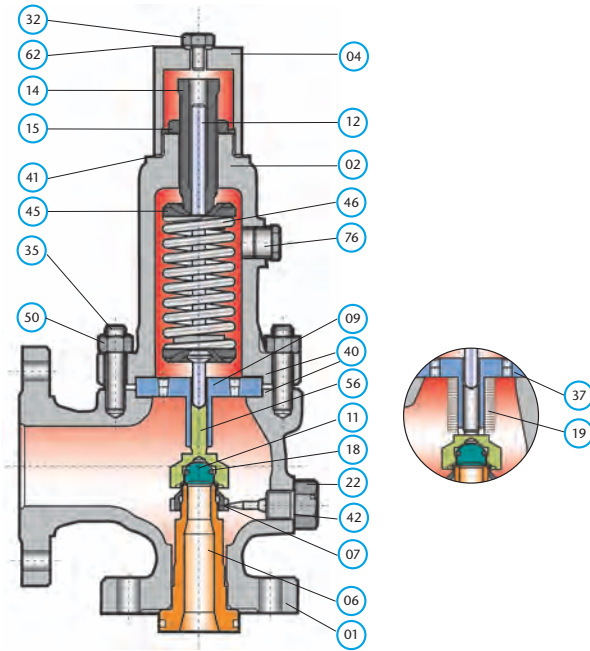

Table 4

Type of Material	US Standard	European Standard & Grade	UNS
Castings			
Carbon steel for high temperature service	SA 216 Gr WCC	GP280GH EN 10213-2	J02503
Killed carbon steel for temperatures down to -46°C	SA 352 Gr LCC	G20Mn5QT EN 10213-3	J02505
Carbon steel for very high temperature service	SA 217 Gr WC6	G17CrMo5-5 EN 10213-2	J12072
Carbon steel for very high temperature service	SA 217 Gr WC9	-	J21890
Austenitic stainless steel	SA 351 Gr CF3M	GxCrNiMo19.11.2 EN 10213-4	J92800
Austenitic stainless steel	SA 351 Gr CF8	Gx5CrNi19.10 EN 10213-4	J92600
Forgings and bars			
Martensitic stainless steel 13 Cr	SA 479 Ty 410	X12Cr13 EN 10088-3	S41000
Ferritic stainless steel 17 Cr - 2Ni	SA 479 Ty 431	X17CrNi16.2 EN 10088-3	
Precipitation hardened stainless steel (17/4 PH)	SA 564 Ty 630	X5CrNiCuNb16.4 EN 10088-3	S17400
Austenitic stainless steel 18 Cr - 10 Ni	SA 479 Ty 304	X5CrNi18.10 EN 10088-3	S30400
Austenitic stainless steel 18 Cr - 10 Ni - 3 Mo	SA 479 Ty 316L	X2CrNiMo17.12.2 EN 10088-3	S31603
Austenitic stainless steel 15 Cr - 25 Ni - 1.25 Mo	SA 638 Gr 660	Z6NCTDV 25-15 EN 10088-3	S66286
Bolting			
Alloy steel 1 Cr - 1/4 Mo	SA 193 Gr B7	42CrMo4 Pr EN 10269	
Low temperature alloy steel	SA 320 Gr L7	42CrMo4 Pr EN 10269	
Austenitic stainless steel 18 Cr - 10 Ni	SA 193 Gr B8	X6CrNi18.10 Pr EN 10629	
Carbon steel nuts	SA 194 Gr 2H	C45E 1 Pr EN 10269	
Stainless steel nuts 18 Cr - 8 Ni	SA 194 Gr 8	X4CrNi18.10 Pr 10269	
Carbon steel nuts for low temperature	SA 194 Gr 4	-	



P3 conventional and P4 balanced types

Materials for standard applications, high temperature, low temperature and corrosive fluids.

For maximum resistance in particularly severe environmental conditions, see the STARFLOW P4 bellows valve specially designed for this application. (see corrosive service application)

For hot water applications where flashing can occur downstream of the seat and nozzle, the bellows type P450 is recommended. (see steam valve).

Notes	Part N°	Part Name	Standard Materials -29°C to +427°C Material code 30	Standard Materials for Low Temperature -45°C to -29°C Material code 19	Standard Materials for Corrosive and Low Temperature down to -60°C Material code 16	Standard Materials for High Temperature up to 538°C Material code 32
	01	Body	SA 216 Gr WCC	SA 352 Gr LCC	SA 351 Gr CF8M	SA 217 Gr WC6
	02	Bonnet	SA 216 Gr WCC	SA 352 Gr LCC	SA 351 Gr CF8M	SA 217 Gr WC6
	04	Cap	CARBON STEEL	CARBON STEEL	SS 316L	CARBON STEEL
1	06	Nozzle	SS 316L	SS 316L	SS 316L	SS 316
1	07	Adjusting ring	A 351 Gr CF3M	A 351 Gr CF3M	A 351 Gr CF3M	A 351 Gr CF3M
1	09	Guide	SS 431	SS 431	SS 316L	SS 431
1	11	Disc	SS 17/4 PH	SS 17/4 PH	SS 316L stellited	SS 316 stellited
	12	Spindle	SS 410	SS 410	SS 316L	SS 410
	14	Adjusting screw	SS 410	SS 410	SS 316L	SS 410
	15	Adjusting screw locknut	SS 316L	SS 316L	SS 316L	SS 316L
1	18	Retaining ring	SS	SS	SS	SS
1,2,3	19	Balanced Bellows	SS 316L	SS 316L	SS 316L	SS 316L
	22	Adjusting ring screw	SS 316L	SS 316L	SS 316L	SS 316L
	35	Bonnet stud	A 193 Gr B7	A 320 Gr L7	A 193 Gr B8	A 193 Gr B16
2,3	37	Bellows plate	SS 316L	SS 316L	SS 316L	SS 316L
1	40	Body/bonnet gasket	SS	SS	SS	SS
1	41	Bonnet/cap gasket	SS	SS	SS	SS
1	42	Adjusting ring screw gasket	SS	SS	SS	SS
1	45	Spring washers (upper & lower)	CARBON STEEL	CARBON STEEL	SS 316L	CARBON STEEL
1	46	Spring	ALLOY STEEL (4)	ALLOY STEEL (4)	SS 316 (5)	ALLOY
	50	Nut	A 194 Gr 2H	A 194 Gr 4	A 194 Gr 8	A 194 Gr 2H
3	56	Disc holder	SS 316L	SS 316L	SS 316L	SS 316L

Notes :

1. Recommended spare parts
2. Bellows type only
3. Bellows sub-assembly
4. Aluminised alloy steel 50CV4
5. 316 up to 300°C - 17.4 PH up to 427 °C - ALLOY up to 538°C
6. Nozzle and disc are SS 316L stellited for pressure class 900 and above

P3 conventional and P4 balanced types

Materials for Cryogenic and Liquefied Natural Gas.

Liquefied Natural Gas and more generally cryogenic applications require special features for the internal materials.

End-users and contractors must be aware that any leakage on cryogenic applications could create an ice ball around the seat and affect the pressure safety valve reliability.

In order to prevent any leakage due to seat damage, Sarasin-RSBD recommend the use of soft seat.

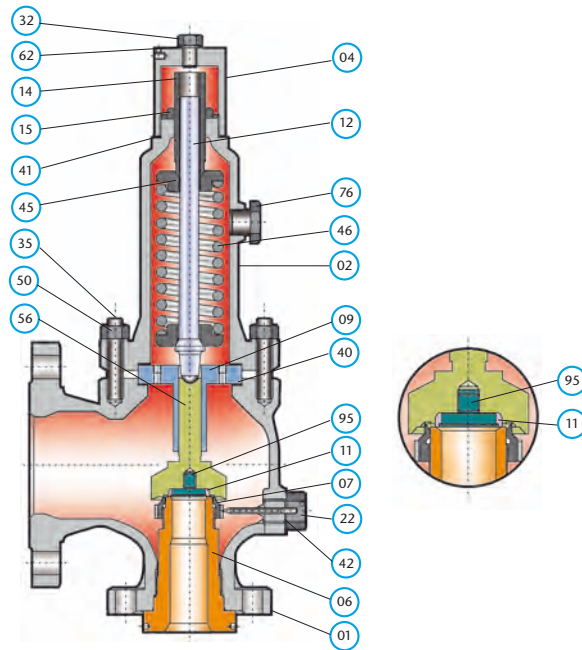

Soft Disc Table

Notes	Part N°	Part Name	Materials for Cryogenic and LNG below -46°C Material code 10
	01	Body	SA 351 Gr CF8M
	02	Bonnet	SA 351 Gr CF8M
	04	Cap	SS 316L
1	06	Nozzle	SS 316L
1	07	Adjusting ring	A 351 Gr CF3M
1	09	Guide	SS 316L
1	11	Disc	(Soft Disc Table)
	12	Spindle	SS 316L
	14	Adjusting screw	SS 316L
	15	Adjusting screw locknut	SS 316L
1,2,3	19	Balanced Bellows	SS 316L
	22	Adjusting ring screw	SS 316L
	35	Bonnet stud	A 320 Gr B8
2,3	37	Bellows plate	SS 316L
1	40	Body/bonnet gasket	SS 316L
1	41	Bonnet/cap gasket	SS 316L
1	42	Adjusting ring screw gasket	SS 316L
1	45	Spring washers (upper & lower)	SS 316L
1	46	Spring	SS 316L
	50	Nut	A 194 Gr 8
3	56	Disc holder	SS 316L
	62	Plug Gasket	SS 316L
	76	Plug	SS 316L
	95	Disc Retainer	SS 316L

Set Pressure (barg)	Seat Material
1 < SP < 26	PTFE
26 < SP < 66	PCTFE
66 < SP < 200	PEEK

Notes :

- 1. Recommended spare parts
- 2. Bellows type only
- 3. Bellows sub-assembly
- 4. Nozzle and disc are SS 316L stellited for pressure class 900 and above

P3 conventional and P4 balanced types

Corrosive and sour gas service

Many process streams in oil and gas industry contain enough H₂S to cause sulfide stress cracking (SSC) in susceptible materials. It exists in two different domains in which two different standards may be applicable:

- Oil and Gas production: NACE MR0175/ISO 15156
 - Part 1 - 2001 : General principles for selection of cracking-resistant materials
 - Part 2 - 2003 : Cracking-resistant carbon and low alloy steels, and the use of cast irons.
 - Part 3 - 2003 : Cracking-resistant CRAs (corrosion-resistant alloys) and other alloys.
- Oil and gas refining: NACE MR0103

The last revisions of NACE MR0175/15156 shows results of the inadequacy of some standard materials commonly used in the oil and gas industry. We then highlight this point and ask the end-user to clearly

specify the condition of use (fluid details, pressure, temperature) in order to be able to select acceptable materials.

Sarasin-RSBD manufactures a large variety of valves used in sour service. Based on our experience and the last edition of the standards, the definition of the actual critical components in a pressure safety valve should be mutually agreed between the purchaser and Weir (Sarasin-RSBD).

Please note, materials are applicable for NACE MR0175 / ISO 15156 according to the different paragraphs of the standard. As a first approach, we can note the following:

Materials	Paragraph
SA 352 Gr LCC	MR0175 / ISO 15156-2 ¶ A2-1-2
SA 216 Gr WCC	MR0175 / ISO 15156-2 ¶ A2-1-2
SA 217 Gr WC6	MR0175 / ISO 15156-2 ¶ A2-1-2
SA 479 Gr 316L	MR0175 / ISO 15156-3 ¶ A2-2 Table 2
UNS S31803	MR0175 / ISO 15156-3 ¶ A7-2 Table 24
UNS N06625	MR0175 / ISO 15156-3 ¶ A4-2 Table 13
UNS N07750	MR0175 / ISO 15156-3 ¶ A2-9 Table 36

As an example of selection, Weir can advise the following valve configuration. The conditions here are not so restrictive: temperature limited to 149 °C (300 °F):

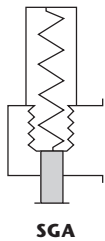

SGA for Starflow P3 & P4: The backpressure side (secondary pressure zone) of the valve is not pressurized under the conditions defined in the NACE specification and therefore not subject to the specification.

Part	SGA	Applicable paragraph	
01	Body	SA 216 Gr WCC	MR0175/ISO 15156-2 § A2-1-2
06/11	Nozzle / Disc	SA 479 Gr 316L	MR0175/ISO 15156-2 § A2-1-2
	Other parts	Standard	

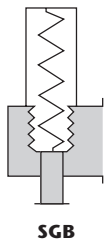

SGB for Starflow P4: The backpressure side of the valve is limited by the bellows. The NACE specification will apply to the wet components located in this area.

Part	SGB	Applicable paragraph	
01	Body	SA 216 Gr WCC	MR0175/ISO 15156-2 § A2-1-2
02	Bonnet	SA 216 Gr WCC	MR0175/ISO 15156-2 § A2-1-2
06/11	Nozzle / Disc	SA 479 Gr 316L	MR0175/ISO 15156-3 § A2-2 Table A2
19	Balanced Bellows (if appl.)	UNS N06625 (ALLOY 625)	MR0175/ISO 15156-3 § A4-2 Table A13
46	P3 Spring P4 Spring	UNS N07750 (ALLOY X750) Alloy Steel	MR0175/ISO 15156-3 § A9-2 Table A36
	Other parts	Standard	

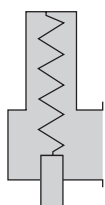

SGB for Starflow P3: The overall valve is subject to the NACE specification.

P3 conventional and P4 balanced types

NICKEL COPPER ALLOY

Application : corrosive fluid

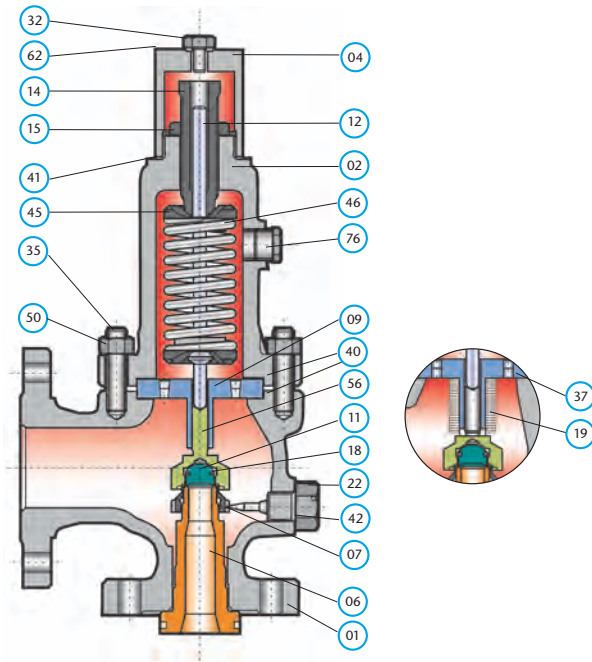

Notes	Part N°	Part Name	NICKEL COPPER ALLOY					
			P3, P4 Material code M1	P4 Only		P3, P4		Material code M6
			Material code M2	Material code M3	Material code M4	Material code M5		
	01	Body	SA 216 Gr WCC(5)	SA 216 Gr WCC(5)	SA 216 Gr WCC(5)	ALLOY 400	ALLOY 400	ALLOY 400
	02	Bonnet	SA 216 Gr WCC(5)	SA 216 Gr WCC(5)	SA 216 Gr WCC(5)	SA 216 Gr WCC(5)	ALLOY 400	ALLOY 400
	04	Cap	CARBON STEEL	CARBON STEEL	CARBON STEEL	CARBON STEEL	ALLOY 400	ALLOY 400
1	06	Nozzle	ALLOY 500	ALLOY 500	ALLOY 500	ALLOY 500	ALLOY 500	ALLOY 500
1	07	Adjusting ring	A 351 Gr CF3M	A 351 Gr CF3M	ALLOY 400	ALLOY 400	ALLOY 400	ALLOY 400
1	09	Guide	SS 431	SS 431	SS 431	SS 431	ALLOY 400	ALLOY 400
1	11	Disc	ALLOY 500	ALLOY 500	ALLOY 500	ALLOY 500	ALLOY 500	ALLOY 500
	12	Spindle	SS 410	SS 410	SS 410	SS 410	ALLOY 400	ALLOY 400
	14	Adjusting screw	SS 410	SS 410	SS 410	SS 410	ALLOY 400	ALLOY 400
	15	Adjusting screw locknut	SS 316L	SS 316L	SS 316L	SS 316L	ALLOY 400	ALLOY 400
1	18	Retaining ring	ALLOY 625	ALLOY 625	ALLOY 625	ALLOY 625	ALLOY 625	ALLOY 625
1,2,3	19	Balanced Bellows	SS 316L	ALLOY 400	ALLOY 400	ALLOY 400	ALLOY 400	ALLOY 400
	22	Adjusting ring screw	SS 316L	SS 316L	ALLOY 400	ALLOY 400	ALLOY 400	ALLOY 400
	35	Bonnet stud	A 193 Gr B7	A 193 Gr B7	A 193 Gr B7	A 193 Gr B7	A 193 Gr B8	A 193 Gr B8
2,3	37	Bellows plate	SS 316L	MONEL	ALLOY 400	ALLOY 400	ALLOY 400	ALLOY 400
1	40	Body/bonnet gasket	SS	SS	ALLOY 400	ALLOY 400	ALLOY 400	ALLOY 400
1	41	Bonnet/cap gasket	SS	SS	ALLOY 400	ALLOY 400	ALLOY 400	ALLOY 400
1	42	Adjusting ring screw gasket	SS	SS	ALLOY 400	ALLOY 400	ALLOY 400	ALLOY 400
1	45	Spring washers (upper & lower)	CARBON STEEL	CARBON STEEL	CARBON STEEL	CARBON STEEL	ALLOY 400	ALLOY 400
1	46	Spring	ALLOY ST. (4)	ALLOY ST. (4)	ALLOY ST. (4)	ALLOY ST. (4)	ALLOY 400	ALLOY X750
	50	Nut	A 194 Gr 2H	A 194 Gr 2H	A 194 Gr 2H	A 194 Gr 2H	A 194 Gr 8	A 194 Gr 8
3	56	Disc holder	SS 316L	SS 316L	ALLOY 400	ALLOY 400	ALLOY 400	ALLOY 400

Notes :

1. Recommended spare parts
2. Bellows type only
3. Bellows sub-assembly
4. Aluminised steel 50CV4
5. Carbon content less than 0.25%, HRC < 22
6. Standard is Alloy 400 UNS J24135 for castings, UNS N04400 for internals excepted that nozzle and disc is UNS N05500.

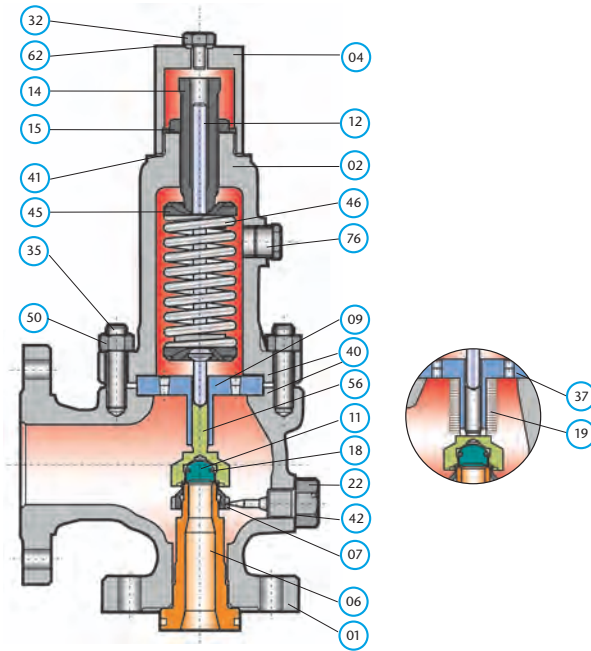

P3 conventional and P4 balanced types

ALLOY C

Application : corrosive fluid

Notes	Part N°	Part Name	ALLOY C				
			P3, P4	P4 Only		P3, P4	
			Material code H1	Material code H2	Material code H3	Material code H4	Material code H6
	01	Body	SA 216 Gr WCC(6)	SA 216 Gr WCC(6)	SA 216 Gr WCC(6)	ALLOY C	ALLOY C
	02	Bonnet	SA 216 Gr WCC(6)	SA 216 Gr WCC(6)	SA 216 Gr WCC(6)	SA 216 Gr WCC(6)	ALLOY C
	04	Cap	CARBON STEEL (6)	CARBON STEEL (6)	CARBON STEEL (6)	CARBON STEEL(6)	ALLOY C
1	06	Nozzle	ALLOY C	ALLOY C	ALLOY C	ALLOY C	ALLOY C
1	07	Adjusting ring	A 351 Gr CF3M	A 351 Gr CF3M	ALLOY C	ALLOY C	ALLOY C
1	09	Guide	SS 431	SS 431	SS 431	SS 431	ALLOY C
1	11	Disc	ALLOY C	ALLOY C	ALLOY C	ALLOY C	ALLOY C
	12	Spindle	SS 410	SS 410	SS 410	SS 410	ALLOY C
	14	Adjusting screw	SS 410	SS 410	SS 410	SS 410	ALLOY C
	15	Adjusting screw locknut	SS 316L	SS 316L	SS 316L	SS 316L	ALLOY C
1	18	Retaining ring	ALLOY 625	ALLOY 625	ALLOY 625	ALLOY 625	ALLOY 625
1,2,3	19	Balanced Bellows	SS 316L	ALLOY C	ALLOY C	ALLOY C	ALLOY C
	22	Adjusting ring screw	SS 316L	SS 316L	ALLOY C	ALLOY C	ALLOY C
	35	Bonnet stud	A 193 Gr B7	A 193 Gr B7	A 193 Gr B7	A 193 Gr B7	A 193 Gr B8
2,3	37	Bellows plate	SS 316L	ALLOY C	ALLOY C	ALLOY C	ALLOY C
1	40	Body/bonnet gasket	SS	SS	ALLOY 400	ALLOY 400	ALLOY 400
1	41	Bonnet/cap gasket	SS	SS	ALLOY 400	ALLOY 400	ALLOY 400
1	42	Adjusting ring screw gasket	SS	SS	ALLOY 400	ALLOY 400	ALLOY 400
1	45	Spring washers (upper & lower)	CARBON STEEL	CARBON STEEL	CARBON STEEL	CARBON STEEL	ALLOY C
1	46	Spring	ALLOY ST. (4)	ALLOY ST. (4)	ALLOY ST. (4)	ALLOY ST. (4)	ALLOY X750 (5)
	50	Nut	A 194 Gr 2H	A 194 Gr 2H	A 194 Gr 2H	A 194 Gr 2H	A 194 Gr 8
3	56	Disc holder	SS 316L	SS 316L	ALLOY C	ALLOY C	ALLOY C

Notes :

1. Recommended spare parts
2. Bellows type only
3. Bellows sub-assembly
4. Aluminised steel 50CV4
5. Alloy C on request
6. Carbon content 0.25%, HRC < 22
7. Standard Alloy C type is UNS 10276

P3 conventional and P4 balanced types

DUPLEX

Application : corrosive fluid and offshore

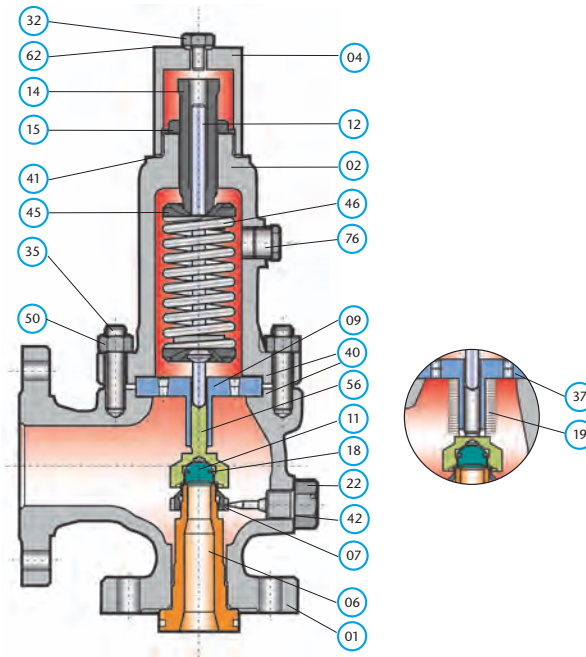

Notes	Part N°	Part Name	DUPLEX					
			P3, P4 Material code D1	P4 Only			P3, P4	
			Material code D2	Material code D3	Material code D4	Material code D5	Material code D6	
	01	Body	SA 216 Gr WCC	SA 216 Gr WCC	SA 216 Gr WCC	DUPLEX (5)	DUPLEX (5)	DUPLEX (5)
	02	Bonnet	SA 216 Gr WCC	SA 216 Gr WCC	SA 216 Gr WCC	SA 216 Gr WCC	DUPLEX (5)	DUPLEX (5)
	04	Cap	CARBON STEEL	CARBON STEEL	CARBON STEEL	CARBON STEEL	DUPLEX (5)	DUPLEX (5)
1	06	Nozzle	DUPLEX (5)	DUPLEX (5)	DUPLEX (5)	DUPLEX (5)	DUPLEX (5)	DUPLEX (5)
1	07	Adjusting ring	A 351 Gr CF3M	A 351 Gr CF3M	DUPLEX (5)	DUPLEX (5)	DUPLEX (5)	DUPLEX (5)
1	09	Guide	SS 431	SS 431	SS 431	SS 431	DUPLEX (5)	DUPLEX (5)
1	11	Disc	DUPLEX (5)	DUPLEX (5)	DUPLEX (5)	DUPLEX (5)	DUPLEX (5)	DUPLEX (5)
	12	Spindle	SS 410	SS 410	SS 410	SS 410	DUPLEX (5)	DUPLEX (5)
	14	Adjusting screw	SS 410	SS 410	SS 410	SS 410	DUPLEX (5)	DUPLEX (5)
	15	Adjusting screw locknut	SS 316L	SS 316L	SS 316L	SS 316L	DUPLEX (5)	DUPLEX (5)
1	18	Retaining ring	ALLOY 625	ALLOY 625	ALLOY 625	ALLOY 625	ALLOY 625	ALLOY 625
1,2,3	19	Balanced Bellows	SS 316L	ALLOY 625	ALLOY 625	ALLOY 625	ALLOY 625	ALLOY 625
	22	Adjusting ring screw	SS 316L	SS 316L	DUPLEX (5)	DUPLEX (5)	DUPLEX (5)	DUPLEX (5)
	35	Bonnet stud	A 193 Gr B7	A 193 Gr B7	A 193 Gr B7	A 193 Gr B7	DUPLEX (5)	DUPLEX (5)
2,3	37	Bellows plate	SS 316L	DUPLEX (5)	DUPLEX (5)	DUPLEX (5)	DUPLEX (5)	DUPLEX (5)
1	40	Body/bonnet gasket	SS	SS	ALLOY 400	ALLOY 400	ALLOY 400	ALLOY 400
1	41	Bonnet/cap gasket	SS	SS	ALLOY 400	ALLOY 400	ALLOY 400	ALLOY 400
1	42	Adjusting ring screw gasket	SS	SS	ALLOY 400	ALLOY 400	ALLOY 400	ALLOY 400
1	45	Spring washers (upper & lower)	CARBON STEEL	CARBON STEEL	CARBON STEEL	CARBON STEEL	ALLOY 400	ALLOY 400
1	46	Spring	ALLOY ST. (4)	ALLOY ST. (4)	ALLOY ST. (4)	ALLOY ST. (4)	SS 316L	ALLOY X750
	50	Nut	A 194 Gr 2H	A 194 Gr 2H	A 194 Gr 2H	A 194 Gr 2H	DUPLEX (5)	DUPLEX (5)
3	56	Disc holder	SS 316L	SS 316L	DUPLEX (5)	DUPLEX (5)	DUPLEX (5)	DUPLEX (5)

Notes :

1. Recommended spare parts
2. Bellows type only
3. Bellows sub-assembly
4. Aluminised steel 50CV4
5. Standard Duplex is UNS J92205 (Duplex G4) for castings and UNS 31803 (22%) for internals
6. Option : Superduplex (25%) UNS 32750 or 32760 on request

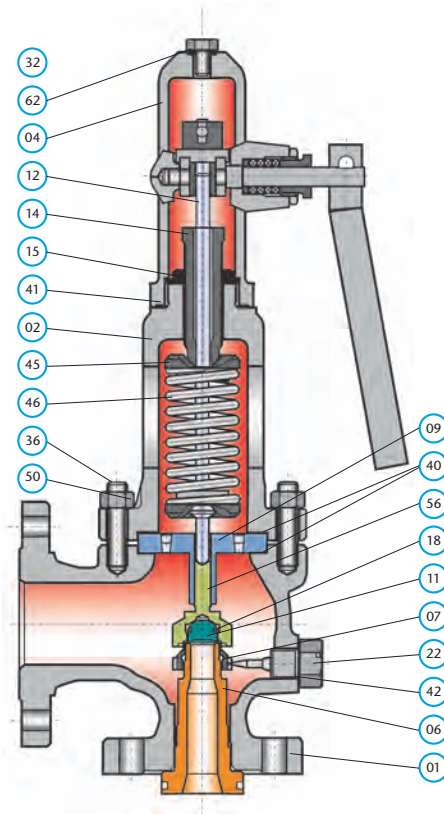

Valves for steam applications P5 with open bonnet or yoke

Valves for hot water applications P3-P4 with closed bonnet and lifting lever

Standard materials

Notes	Part N°	Part Name	P5 Standard Materials		P3/P4
			Up to 427°C Material code 30	From 427 to 538°C Material code 32 (7)	Up to 427°C Material code 50 (6)
	01	Body	SA 216 Gr WCC	SA 217 Gr WC6	SA 216 Gr WCC
	02	Yoke (1)	SA 216 Gr WCC	SA 216 Gr WCC	SA 216 Gr WCC
	04	Cap	SA 216 Gr WCC	SA 216 Gr WCC	SA 216 Gr WCC
1	06	Nozzle	SS 410 stelled	SS 316 stelled	SS 410 stelled
1	07	Adjusting ring	A 351 Gr CF3M	A 351 Gr CF3M	A 351 Gr CF3M
1	09	Guide	SS 431	SS 431	SS 431
1	11	Disc	SS 17/4 PH	SS 316L stelled	SS 17/4 PH
	12	Spindle	SS 410	SS 410	SS 410
	14	Adjusting screw	SS 410	SS 410	SS 410
	15	Adjusting screw locknut	SS 316L	SS 316L	SS 316L
1	18	Retaining ring	SS	SS	SS
1,2,3	19	Balanced Bellows			SS 316L
	22	Adjusting ring screw	SS 316L	SS 316L	SS 316L
	35	Bonnet stud	A 193 Gr B7	A 194 Gr B16	A 193 B7
2,3	37	Bellows plate			SS 316L
1	40	Body/bonnet gasket	SS	SS	SS
1	41	Bonnet/cap gasket	SS	SS	SS
1	42	Adjusting ring screw gasket	SS	SS	SS
1	45	Spring washers (upper & lower)	CARBON STEEL	CARBON STEEL	CARBON STEEL
1	46	Spring	ALLOY STEEL	ALLOY STEEL	ALLOY STEEL
	50	Nut	A 194 Gr 2H	A 194 Gr 2H	A 194 Gr 2H
3	56	Disc holder	SS 316L	SS 316L	SS 316L

Notes :

1. Recommended spare parts
2. Bellows type only
3. Bellows sub-assembly
4. Lever is mandatory on steam applications according to ASME, API and ISO standards and some local laws.
5. Open bonnet for code 30 and 32 (till P orifice - Yoke from Q orifice)
6. Lever required for code 50
7. The code was previously '02'

Valves for steam application S5 with open bonnet or yoke

Standard materials

Starflow S5 has been specifically designed for steam process applications.

The main improved features compared to a standard API valve design are :

- Enlarged guide to guarantee improved gliding.
- Thermoglide rings to improve gliding and avoid seizing.
- Intrinsically balanced : allows up to 50% back-pressure within the outlet flange rating limits.

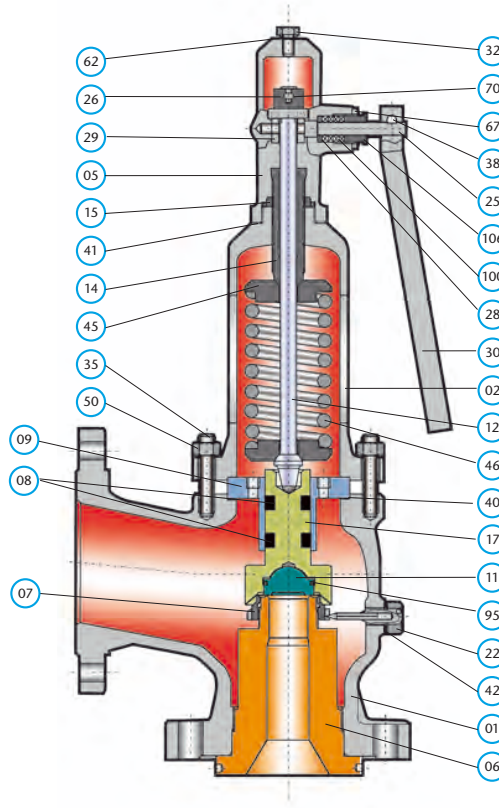

Notes	Part N°	Part Name	S5 Standard Materials	
			Up to 427°C Material code 30	From 427 to 538°C Material code 02
1	01	Body	SA 216 Gr WCC	SA 217 Gr WC6
	02	Yoke	SA 216 Gr WCC	SA 216 Gr WCC
	05	Cap	SA 216 Gr WCC	SA 216 Gr WCC
	06	Nozzle	SS 316 stellited	SS 316 stellited
	07	Adjusting ring	A 351 Gr CF3M	A 351 Gr CF3M
	08	Disc Holder Ring	Thermoglide™	Thermoglide™
	09	Guide	SS 431	SS 431
	11	Disc	SS 660	SS 660
	12	Spindle	SS 410	SS 410
	14	Adjusting screw	SS 410	SS 410
	15	Adjusting screw locknut	SS 316L	SS 316L
	22	Adjusting ring screw	SS 316L	SS 316L
	25	Fork Shaft	SS 316L	SS 316L
	26	Spindle Nut	SS 316L	SS 316L
	28	Lever Ring	SS 316L	SS 316L
	29	Lever Fork	SA 351 Gr. CF3M	SA 351 Gr. CF3M
	30	Lever	CARBON STEEL	CARBON STEEL
	32	Cap Plug	STAINLESS STEEL	STAINLESS STEEL
35	Bonnet stud	A 193 Gr B7	A 194 Gr B16	
40	Body/bonnet gasket	SS	SS	
41	Bonnet/cap gasket	SS	SS	
42	Adjusting ring screw gasket	SS	SS	
45	Spring washers (upper & lower)	CARBON STEEL	CARBON STEEL	
46	Spring	ALLOY STEEL	ALLOY STEEL	
50	Nut	A 194 Gr 2H	A 194 Gr 2H	
56	Disc Holder	SS 316L	SS 316L	
62	Plug Gasket	STAINLESS STEEL	STAINLESS STEEL	
67	Lever Nut	SS 316L	SS 316L	
95	Retaining ring	SS	SS	

Notes :

1. Open bonnet till P orifice - Yoke from Q orifice

Cap Types

Screwed cap (standard)

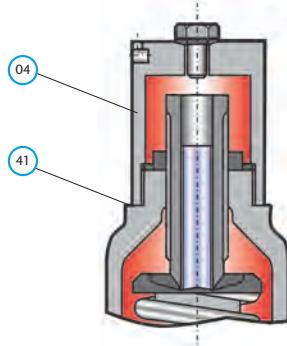

Bolted cap

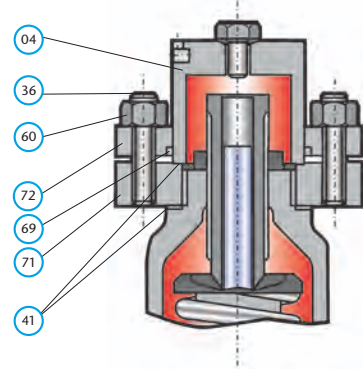

Packed lever (standard)

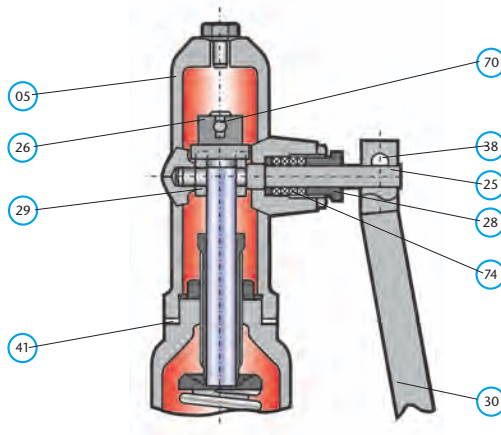

Bolted (and packed) lever

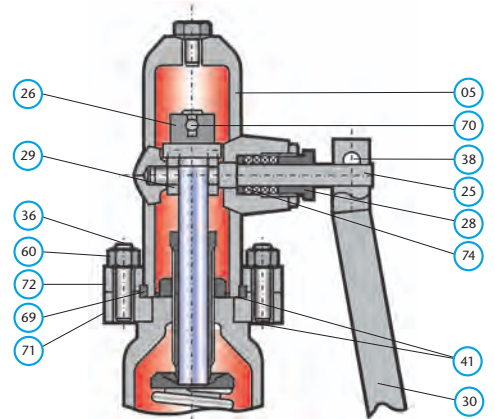

Part N°	Part Name	Standard Materials (3)	SS Materials (3)
04	Cap (1)	CARBON STEEL	SS 316L
05	Cap with lever (2)	A 216 Gr WCC	A 351 Gr CF8M
25	Shaft	SS 316L	SS 316L
26	Stem nut	SS 316L	SS 316L
28	Packing press	SS 316L	SS 316L
29	Fork	A 351 Gr CF3M	A 351 Gr CF3M
30	Lever	CARBON STEEL	SS
36	Threaded rod	A 193 Gr B7	A 193 Gr B8T
38	Key	CARBON STEEL	CARBON STEEL
41	Gasket	SS	SS
60	Nuts	A 194 Gr 2H	A 194 Gr 8
69	Retainer ring	SS	SS
70	Pin	SS	SS
71	Lower flange	CARBON STEEL	SS 316L
72	Upper flange	CARBON STEEL	SS 316L
74	Packing	GRAPHITE	PTFE

Notes :

- (1) Possibility of spindle with threaded end to check set pressure in situ
- (2) Exists in open version
- (3) Other materials available according to bill of materials

Standard options

- Inlet and outlet flange : specify flange standard and surface finish if different from standard. ASME B16.5 flanges are identical to EN 1759 flanges.
- Test gag : optional (sometimes named transportation gag)
- Lifting device : STARFLOW safety relief valves, with the exception of the P5 model (open bonnet for steam applications) as well as models P450 and P350 (closed bonnet, balanced bellows or not, for hot water applications) are normally supplied without lifting device. If the lifting device is necessary it has to be specified for example, to comply with ASME. Lifting devices may be plain or packed depending on the service requirements.
- Spring material : standard spring materials are those specified in the various bills of material. However, it is possible to specify other spring materials such as tungsten steel, stainless steel, Alloy X750, 17/4 PH etc.
- "STARSOFT" SOFT SEATED VALVE : all STARFLOW safety relief valves can be supplied with a "STARSOFT" soft seat as an option. We strongly encourage the user to select the soft material which is suitable for the intended service. Please check the temperature and chemical compatibility. Without any other specification from the customer, Fluorocarbon will be selected as standard material.
- Bellows material different from AISI 316L (such as Alloy 400 or Alloy 625) can be specified.
- The valves can be steam tested. Any kind of size can be tested upto 85 barg (for small sizes).

Options and special accessories

- Inlet flange to customer's specification
- Outlet flange to customer's specification or outlet flange rating above class 150 lbs rating
- Remotely controlled lifting device
- Change in standard bills of material
- Accessories such as cooling spool, valve lift indicator, leak detector, steam jacket, etc. In case of special options or accessories specification, sufficient information should be supplied to the factory to avoid misunderstanding.

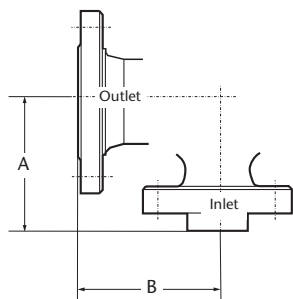

Nominal inlet diameter <4" A and B ± 1.6 mm
Nominal outlet diameter >4" A and B ± 3.2 mm

Options and Accessories

Steam jacket

In order to avoid solidification of the fluid in certain process lines, STARFLOW safety relief valves may be supplied with a steam jacket.

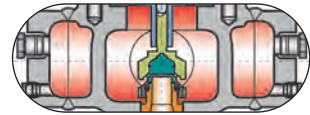

Cooling spool

STARFLOW safety relief valves can be supplied with a cooling spool so as to protect the spring from the fluid temperature.

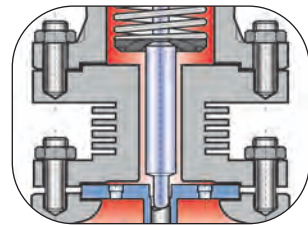

Leak detector

This device can be fitted to balanced bellows safety relief valves to indicate any damage or leakage of the bellows. An indicator switch can also be added to the leak detector.

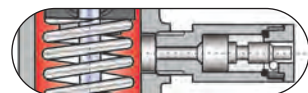

Remote Control Lifting Device

All STARFLOW valves can be equipped with a remote controlled pneumatic lifting device.

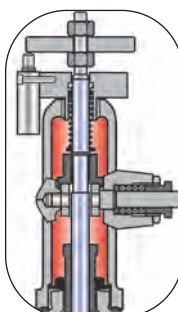
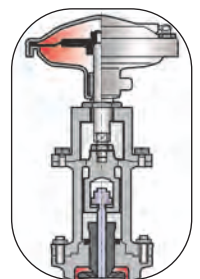

Valve opening detector

Electrical switch or explosion proof device indicating valve opening.

Orifice tables

Starflow

Orifice	D	E	F	G	H	J	K	L	M	N	P	Q	R	T	V	W
Actual in ²	0.134	0.273	0.373	0.589	0.881	1.457	2.097	3.284	4.093	4.987	7.215	12.91	17.81	28.87	46.75	70.10
API in ²	0.11	0.196	0.307	0.503	0.785	1.287	1.838	2.853	3.6	4.34	6.38	11.05	16	26	-	-
Actual cm ²	0.865	1.76	2.406	3.800	5.684	9.400	13.52	21.42	26.42	32.16	46.55	83.53	114.9	186.2	301.6	452.3
API cm ²	0.71	1.26	1.98	3.24	5.06	8.30	11.86	18.41	23.2	28.0	41.2	71.2	103.2	167.8	-	-

Starflow P Series Selection Tables

How to use the selection tables

The correct STARFLOW model number may be selected by using the following selection tables or the selection diagrams.

These tables and have been established according to API STD 526 last edition, whilst the diagrams have been established according to ASME B16.34 last edition.

There are selection tables and selection diagrams for each orifice size from D to T (API STD 526) +V and W (ASME B16.34).

When the valve orifice size has been selected according to the duty requirements as well as the applicable sizing formula or capacity table (see the sizing section in our technical information catalogue), select the applicable selection table or diagram.

In the applicable selection table or diagram, for the specified service temperature, select the valve in accordance with the required set pressure. Selection diagrams should be used for interpolations.

The table or diagram then specifies the 5 first digits of the STARFLOW coding system. The table also shows the 3 following digits which refer to the service conditions (conventional-balanced bellows steam), as well as the inlet and outlet sizes and ratings, the maximum allowable back pressure and the body and spring materials.

Refer to the table of dimensions for geometric data and weight.

Example :

What is the model number for a 'D' orifice, set at 40 barg and 135°C ?

- Go to the 'D' orifice selection chart and find the location of the intersection 135°C - 40 barg
- Read the model number : P12D2330 (conventional), 1" x D x 2" rating 300 lbs, inlet 1" - 300 lbs, outlet 2" - 150 lbs, A = 104.8 mm, B = 114.3 mm, weight : 18 kg.

Notes :

These tables and diagrams have been issued according to API STD 526 and ASME B16.34. Therefore they do not take into consideration such parameters as corrosion and special service requirements. This data should be considered when selecting a model number. Refer to the section of this catalogue dealing with the different bills of material.

ORIFICE : D
0.71 cm²
0.11 in²

Starflow P Series Selection Table
 According to API Std 526 : (edition 2009)

INLETx ORIFICEx OUTLET	ANSI FLANGE RATING		Model Number	Conventional	Bellows	Steam service	MAX. SET PRESSURE barg (psig)					MAX. BACK PRESSURE (1) barg (psig)		Body	Spring	
	Inlet	Outlet					-268°C to -47°C (-450°F to -51°F)	-46°C to -29°C (-50°F to -21°F)	-29°C to +38°C (-20°F to 100°F)	<232°C (<450°F)	<427°C (<800°F)	<538°C (<1000°F)	Conventional			Bellows
1 D 2	150	150	P12D1	330	430	530			19.8 (285)	13 (185)	5.5 (80)		19.8 (285)	16 (230)	SA 216 Gr. WCC	Alloy Steel
1 D 2	300	150	P12D7	330	430	530			19.8 (285)	19.8 (285)	19.8 (285)		19.8 (285)	16 (230)		
1 D 2	300	150	P12D2	330	430	530			51 (740)	42.4 (615)	29 (410)		19.8 (285)	16 (230)		
1 D 2	600	150	P12D3	330	430	530			102 (1480)	85 (1235)	58 (825)		19.8 (285)	16 (230)		
1½ D 2	900	300	P72D4	330	430	530			153 (2220)	128 (1845)	86 (1235)		41 (600)	35 (500)		
1½ D 2	1500	300	P72D5	330	430	530			255 (3705)	213 (3080)	144 (2060)		41 (600)	35 (500)		
1½ D 3 (4)	2500	300	P73D6	330	430	530			414 (6000)	414 (6000)	240 (3430)		51 (740)	35 (500)		
1 D 2	300	150	P12D2	332	432	502					35 (510)	16 (225)	19.8 (285)	16 (230)	SA 216 Gr. WC6	High Temp. Alloy Steel
1 D 2	600	150	P12D3	332	432	502					70 (1015)	32 (445)	19.8 (285)	16 (230)		
1½ D 2	900	300	P72D4	332	432	502					105 (1525)	46 (670)	41 (600)	35 (500)		
1½ D 2	1500	300	P72D5	332	432	502					176 (2540)	79 (1115)	41 (600)	35 (500)		
1½ D 3 (4)	2500	300	P73D6	332	432	502					293 (4230)	128 (1860)	51 (740)	35 (500)		
1 D 2	150	150	P12D1	319	419			19.8 (285)					19.8 (285)	16 (230)	SA 352 Gr. LCC	Alloy Steel
1 D 2	300	150	P12D7	319	419			19.8 (285)					19.8 (285)	16 (230)		
1 D 2	300	150	P12D2	319	419			51 (740)					19.8 (285)	16 (230)		
1 D 2	600	150	P12D3	319	419			102 (1480)					19.8 (285)	16 (230)		
1½ D 2	900	300	P72D4	319	419			153 (2220)					41 (600)	35 (500)		
1½ D 2	1500	300	P72D5	319	419			255 (3705)					41 (600)	35 (500)		
1½ D 3 (4)	2500	300	P73D6	319	419			414 (6000)					51 (740)	35 (500)		
1 D 2	150	150	P12D1	316	416		19 (275)						19 (275)	16 (230)	SA 351 Gr. CF8M	Stainless Steel
1 D 2	300	150	P12D7	316	416		19 (275)						19 (275)	16 (230)		
1 D 2	300	150	P12D2	316	416		50 (720)						19 (275)	16 (230)		
1 D 2	600	150	P12D3	316	416		99 (1440)						19 (275)	16 (230)		
1½ D 2	900	300	P72D4	316	416		149 (2160)						41 (600)	35 (500)		
1½ D 2	1500	300	P72D5	316	416		248 (3600)						41 (600)	35 (500)		
1½ D 3 (4)	2500	300	P73D6	316	416		276 (4000)						50 (720)	35 (500)		

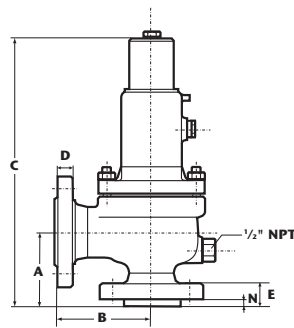

INLETx ORIFICEx OUTLET	ANSI FLANGE RATING		MODEL NUMBER	A(2)	B(2)	C	D	E	N	Approximate weight (3)
	Inlet	Outlet		mm (in)	mm (in)	mm (in)	mm (in)	mm (in)	mm (in)	kg (lbs)
1 D 2	150	150	P12D1	104.8 (4-1/8)	114.3 (4-1/2)	375 (15)	19.1 (3/4)	31 (1-1/8)	12 (1/2)	18 (40)
1 D 2	300	150	P12D7	104.8 (4-1/8)	114.3 (4-1/2)	375 (15)	19.1 (3/4)	31 (1-1/8)	12 (1/2)	18 (40)
1 D 2	300	150	P12D2	104.8 (4-1/8)	114.3 (4-1/2)	375 (15)	19.1 (3/4)	31 (1-1/8)	12 (1/2)	18 (40)
1 D 2	600	150	P12D3	104.8 (4-1/8)	114.3 (4-1/2)	375 (15)	19.1 (3/4)	31 (1-1/8)	12 (1/2)	19 (42)
1½ D 2	900	300	P72D4	104.8 (4-1/8)	139.7 (5-1/2)	480 (19)	22.4 (7/8)	46 (1-3/16)	13 (1/2)	35 (77)
1½ D 2	1500	300	P72D5	104.8 (4-1/8)	139.7 (5-1/2)	480 (19)	22.4 (7/8)	46 (1-3/16)	13 (1/2)	36 (79)
1½ D 3 (4)	2500	300	P73D6	139.7 (5-1/2)	177.8 (7)	505 (20)	28.4 (1-1/8)	59 (2-3/16)	13 (1/2)	45 (99)

- (1) Max. back pressure limits at 38°C; for higher temp. refer to ASME B16.5 flange ratings for conventional valves
- (2) Tolerances for A and B : ± 1.6 mm (± 1/16 in)
- (3) Valves with lifting lever : add 10%
- (4) 2½" outlet flange on request in conformity with API Std 526 ed.84, model becomes P75D6

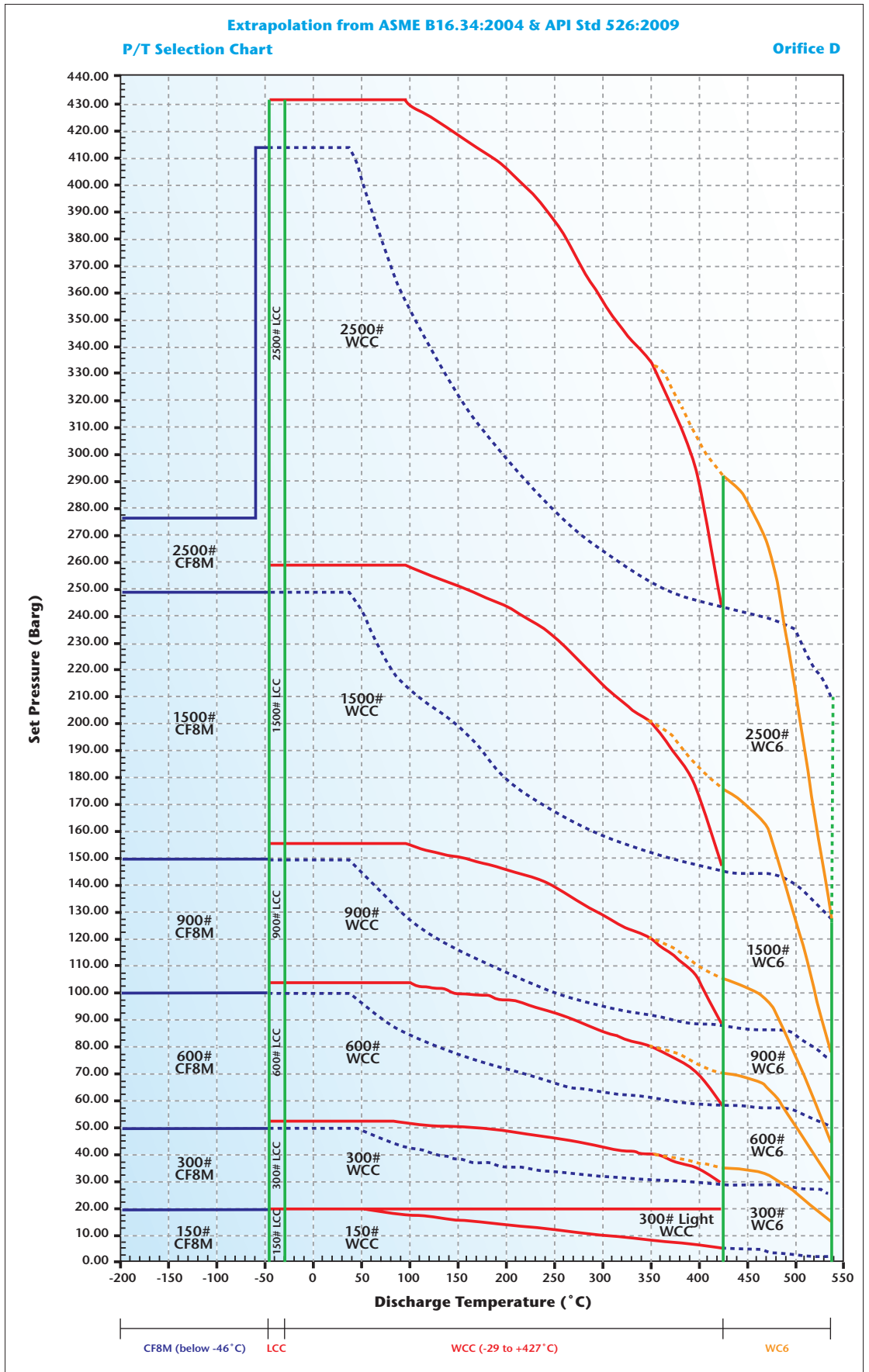

ORIFICE : E
1.26 cm²
0.196 in²

Starflow P Series Selection Table
 According to API Std 526 : (edition 2009)

INLETx ORIFICEx OUTLET	ANSI FLANGE RATING		Model Number	Conventional	Bellows	Steam service	MAX. SET PRESSURE barg (psig)					MAX. BACK PRESSURE (1) barg (psig)		Body	Spring	
	Inlet	Outlet					-268°C to -47°C (-450°F to -51°F)	-46°C to -29°C (-50°F to -21°F)	-29°C to +38°C (-20°F to 100°F)	<232°C (<450°F)	<427°C (<800°F)	<538°C (<1000°F)	Conventional			Bellows
1 E 2	150	150	P12E1	330	430	530			19.8 (285)	13 (185)	5.5 (80)		19.8 (285)	16 (230)	SA 216 Gr. WCC	Alloy Steel
1 E 2	300	150	P12E7	330	430	530			19.8 (285)	19.8 (285)	19.8 (285)		19.8 (285)	16 (230)		
1 E 2	300	150	P12E2	330	430	530			51 (740)	42.4 (615)	29 (410)		19.8 (285)	16 (230)		
1 E 2	600	150	P12E3	330	430	530			102 (1480)	85 (1235)	58 (825)		19.8 (285)	16 (230)		
1½ E 2	900	300	P72E4	330	430	530			153 (2220)	128 (1845)	86 (1235)		41 (600)	35 (500)		
1½ E 2	1500	300	P72E5	330	430	530			255 (3705)	213 (3080)	144 (2060)		41 (600)	35 (500)		
1½ E 3 (4)	2500	300	P73E6	330	430	530			414 (6000)	414 (6000)	240 (3430)		51 (740)	35 (500)		
1 E 2	300	150	P12E2	332	432	502					35 (510)	16 (225)	19.8 (285)	16 (230)	SA 216 Gr. WC6	High Temp. Alloy Steel
1 E 2	600	150	P12E3	332	432	502					70 (1015)	32 (445)	19.8 (285)	16 (230)		
1½ E 2	900	300	P72E4	332	432	502					105 (1525)	46 (670)	41 (600)	35 (500)		
1½ E 2	1500	300	P72E5	332	432	502					176 (2540)	79 (1115)	41 (600)	35 (500)		
1½ E 3 (4)	2500	300	P73E6	332	432	502					293 (4230)	128 (1860)	51 (740)	35 (500)		
1 E 2	150	150	P12E1	319	419			19.8 (285)					19.8 (285)	16 (230)	SA 352 Gr. LCC	Alloy Steel
1 E 2	300	150	P12E7	319	419			19.8 (285)					19.8 (285)	16 (230)		
1 E 2	300	150	P12E2	319	419			51 (740)					19.8 (285)	16 (230)		
1 E 2	600	150	P12E3	319	419			102 (1480)					19.8 (285)	16 (230)		
1½ E 2	900	300	P72E4	319	419			153 (2220)					41 (600)	35 (500)		
1½ E 2	1500	300	P72E5	319	419			255 (3705)					41 (600)	35 (500)		
1½ E 3 (4)	2500	300	P73E6	319	419			414 (6000)					51 (740)	35 (500)		
E 2	150	150	P12E1	316	416		19 (275)						19 (275)	16 (230)	SA 351 Gr. CF8M	Stainless Steel
1 E 2	300	150	P12E7	316	416		19 (275)						19 (275)	16 (230)		
1 E 2	300	150	P12E2	316	416		50 (720)						19 (275)	16 (230)		
1 E 2	600	150	P12E3	316	416		99 (1440)						19 (275)	16 (230)		
1½ E 2	900	300	P72E4	316	416		149 (2160)						41 (600)	35 (500)		
1½ E 2	1500	300	P72E5	316	416		248 (3600)						41 (600)	35 (500)		
1½ E 3 (4)	2500	300	P73E6	316	416		276 (4000)						50 (720)	35 (500)		

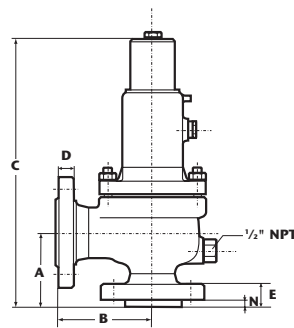

INLETx ORIFICEx OUTLET	ANSI FLANGE RATING		MODEL NUMBER	A(2)	B(2)	C	D	E	N	Approximate weight (3)
	Inlet	Outlet		mm (in)	mm (in)	mm (in)	mm (in)	mm(in)	mm (in)	kg (lbs)
1E2	150	150	P12E1	104.8 (4-1/8)	114.3 (4-1/2)	375 (15)	19.1 (3/4)	31 (1-1/4)	12 (1/2)	18 (40)
1E2	300	150	P12E7	104.8 (4-1/8)	114.3 (4-1/2)	375 (15)	19.1 (3/4)	31 (1-1/4)	12 (1/2)	18 (40)
1E2	300	150	P12E2	104.8 (4-1/8)	114.3 (4-1/2)	375 (15)	19.1 (3/4)	31 (1-1/4)	12 (1/2)	18 (40)
1E2	600	150	P72E3	104.8 (4-1/8)	114.3 (4-1/2)	375 (15)	19.1 (3/4)	31 (1-1/4)	12 (1/2)	19 (42)
1½ E 2	900	300	P72E4	104.8 (4-1/8)	139.7 (5-1/2)	480 (19)	22.4 (7/8)	46 (1-13/16)	13 (1/2)	35 (77)
1½ E 2	1500	300	P72E5	104.8 (4-1/8)	139.7 (5-1/2)	480 (19)	22.4 (7/8)	46 (1-13/16)	13 (1/2)	36 (79)
1½ E 3 (4)	2500	300	P73E6	139.7 (5-1/2)	177.8 (7)	505 (20)	28.4 (1-1/2)	59 (2-3/16)	13 (1/2)	45 (99)

- (1) Max. back pressure limits at 38°C; for higher temp. refer to ASME B16.5 flange ratings for conventional valves
- (2) Tolerances for A and B : ± 1.6 mm (± 1/8 in)
- (3) Valves with lifting lever : add 10%
- (4) 2½" outlet flange on request in conformity with API Std 526 ed. 84, model becomes P75E6

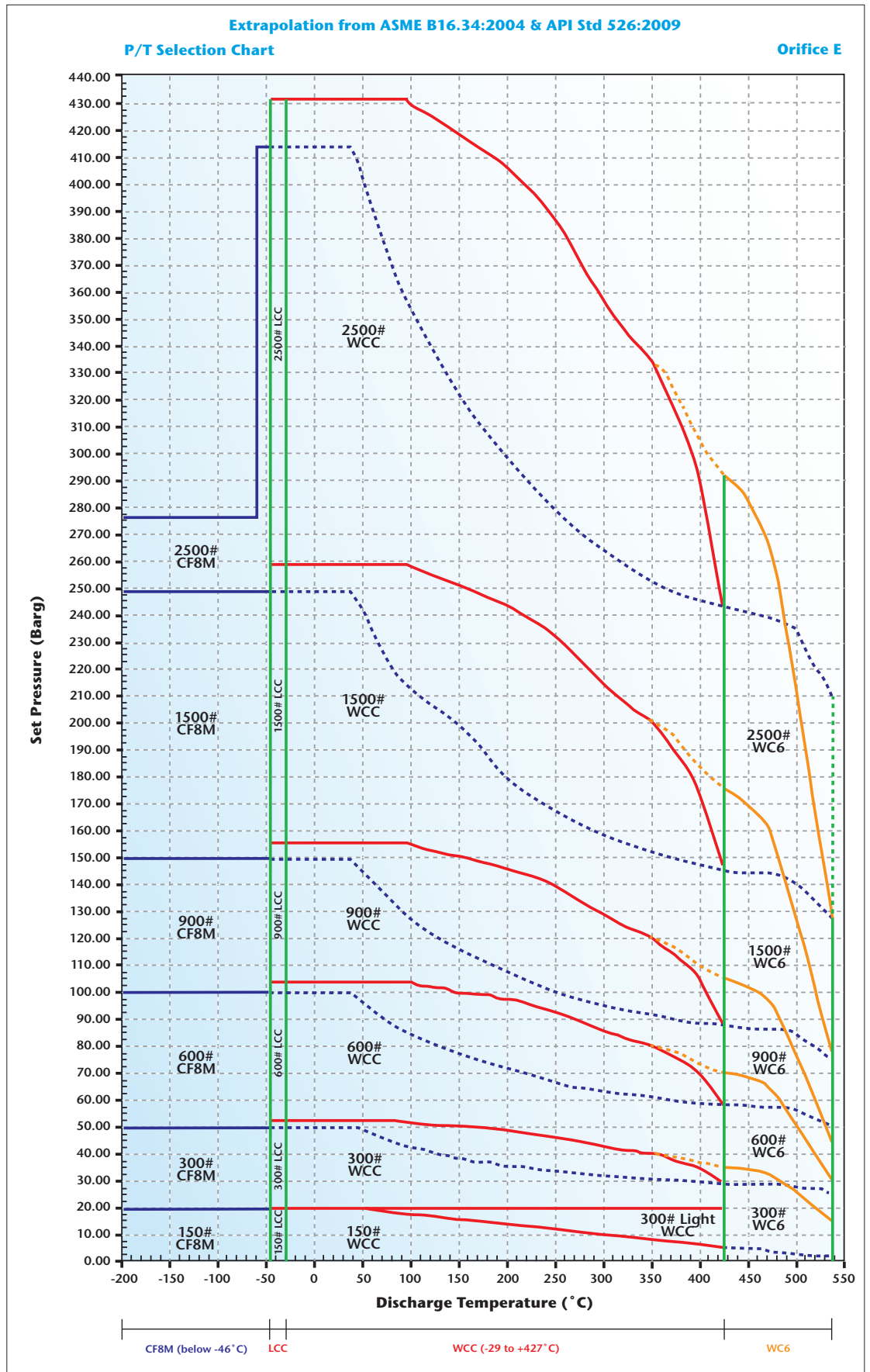

ORIFICE : F
1.98 cm²
0.307 in²

Starflow P Series Selection Table
 According to API Std 526 : (edition 2009)

INLETx ORIFICEx OUTLET	ANSI FLANGE RATING		Model Number	Conventional	Bellows	Steam service	MAX. SET PRESSURE barg (psig)					MAX. BACK PRESSURE (1) barg (psig)		Body	Spring	
	Inlet	Outlet					-268°C to -47°C (-450°F to -51°F)	-46°C to -29°C (-50°F to -21°F)	-29°C to +38°C (-20°F to 100°F)	<232°C (<450°F)	<427°C (<800°F)	<538°C (<1000°F)	Conventional			Bellows
1 1/2 F 2	150	150	P72F1	330	430	530			19.8 (285)	13 (185)	5.5 (80)		19.8 (285)	16 (230)	SA 216 Gr. WCC	Alloy Steel
1 1/2 F 2	300	150	P72F7	330	430	530			19.8 (285)	19.8 (285)	19.8 (285)		19.8 (285)	16 (230)		
1 1/2 F 2	300	150	P72F2	330	430	530			51 (740)	42.4 (615)	29 (410)		19.8 (285)	16 (230)		
1 1/2 F 2	600	150	P72F3	330	430	530			102 (1440)	85 (1235)	58 (825)		19.8 (285)	16 (230)		
1 1/2 F 3 (4)	900	300	P73F4	330	430	530			153 (2220)	128 (1845)	85 (1235)		51 (740)	34 (500)		
1 1/2 F 3 (4)	1500	300	P73F5	330	430	530			255 (3705)	213 (3080)	144 (2060)		51 (740)	34 (500)		
1 1/2 F 3 (4)	2500	300	P73F6	330	430	530			345 (5000)	345 (5000)	240 (3430)		51 (740)	34 (500)		
1 1/2 F 2	300	150	P72F2	332	432	502					35 (510)	15 (225)	19.8 (285)	16 (230)	SA 216 Gr. WC6	High Temp. Alloy Steel
1 1/2 F 2	600	150	P72F3	332	432	502					70 (1015)	31 (445)	19.8 (285)	16 (230)		
1 1/2 F 3 (4)	900	300	P73F4	332	432	502					105 (1525)	46 (670)	51 (740)	34 (500)		
1 1/2 F 3 (4)	1500	300	P73F5	332	432	502					175 (2540)	77 (1115)	51 (740)	34 (500)		
1 1/2 F 3 (4)	2500	300	P73F6	332	432	502					292 (4230)	128 (1860)	51 (740)	34 (500)		
1 1/2 F 2	150	150	P72F1	319	419			19.8 (285)					19.8 (285)	16 (230)	SA 352 Gr. LCC	Alloy Steel
1 1/2 F 2	300	150	P72F7	319	419			19.8 (285)					19.8 (285)	16 (230)		
1 1/2 F 2	300	150	P72F2	319	419			51 (740)					19.8 (285)	16 (230)		
1 1/2 F 2	600	150	P72F3	319	419			102 (1440)					19.8 (285)	16 (230)		
1 1/2 F 3 (4)	900	300	P73F4	319	419			153 (2220)					51 (740)	34 (500)		
1 1/2 F 3 (4)	1500	300	P73F5	319	419			255 (3705)					51 (740)	34 (500)		
1 1/2 F 3 (4)	2500	300	P73F6	319	419			345 (5000)					51 (740)	34 (500)		
1 1/2 F 2	150	150	P72F1	316	416		19 (275)						19 (275)	16 (230)	SA 351 Gr. CF8M	Stainless Steel
1 1/2 F 2	300	150	P72F7	316	416		19 (275)						19 (275)	16 (230)		
1 1/2 F 2	300	150	P72F2	316	416		50 (720)						19 (275)	16 (230)		
1 1/2 F 2	600	150	P72F3	316	416		99 (1440)						19 (275)	16 (230)		
1 1/2 F 3 (4)	900	300	P73F4	316	416		149 (2160)						50 (720)	34 (500)		
1 1/2 F 3 (4)	1500	300	P73F5	316	416		152 (2200)						50 (720)	34 (500)		
1 1/2 F 3 (4)	2500	300	P73F6	316	416		234 (3400)						50 (720)	34 (500)		

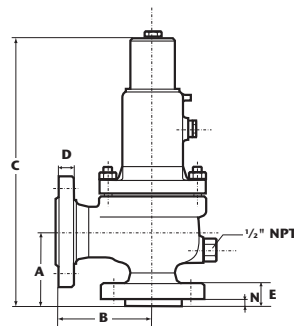

INLETx ORIFICEx OUTLET	ANSI FLANGE RATING		MODEL NUMBER	A(2)	B(2)	C	D	E	N	Approximate weight (3)
	Inlet	Outlet		mm (in)	mm (in)	mm (in)	mm (in)	mm (in)	mm (in)	kg (lbs)
1 1/2 F 2	150	150	P72F1	123.8 (4-7/8)	120.7 (4-3/4)	455 (18)	19.1 (3/4)	34 (1-3/16)	12 (1/2)	25 (55)
1 1/2 F 2	300	150	P72F7	123.8 (4-7/8)	120.7 (4-3/4)	455 (18)	19.1 (3/4)	36 (1-3/8)	12 (1/2)	27 (60)
1 1/2 F 2	300	150	P72F2	123.8 (4-7/8)	152.4 (6)	455 (18)	19.1 (3/4)	36 (1-3/8)	12 (1/2)	27 (60)
1 1/2 F 2	600	150	P72F3	123.8 (4-7/8)	152.4 (6)	455 (18)	19.1 (3/4)	36 (1-3/8)	12 (1/2)	31 (68)
1 1/2 F 3 (4)	900	300	P73F4	123.8 (4-7/8)	165.1 (6-1/2)	505 (20)	28.4 (1-1/8)	46 (1-13/16)	13 (1/2)	44 (97)
1 1/2 F 3 (4)	1500	300	P73F5	123.8 (4-7/8)	165.1 (6-1/2)	505 (20)	28.4 (1-1/8)	46 (1-13/16)	13 (1/2)	44 (97)
1 1/2 F 3 (4)	2500	300	P73F6	139.7 (5-1/2)	177.8 (7)	505 (20)	28.4 (1-1/8)	59 (2-3/16)	13 (1/2)	48 (108)

- (1) Max. back pressure limits at 38°C; for higher temp. refer to ASME B16.5 flange ratings for conventional valves
- (2) Tolerances for A and B : ± 1.6 mm (± 1/16 in)
- (3) Valves with lifting lever : add 10%
- (4) 2 1/2" outlet flange on request in conformity with API Std 526 ed. 84, model becomes P75F

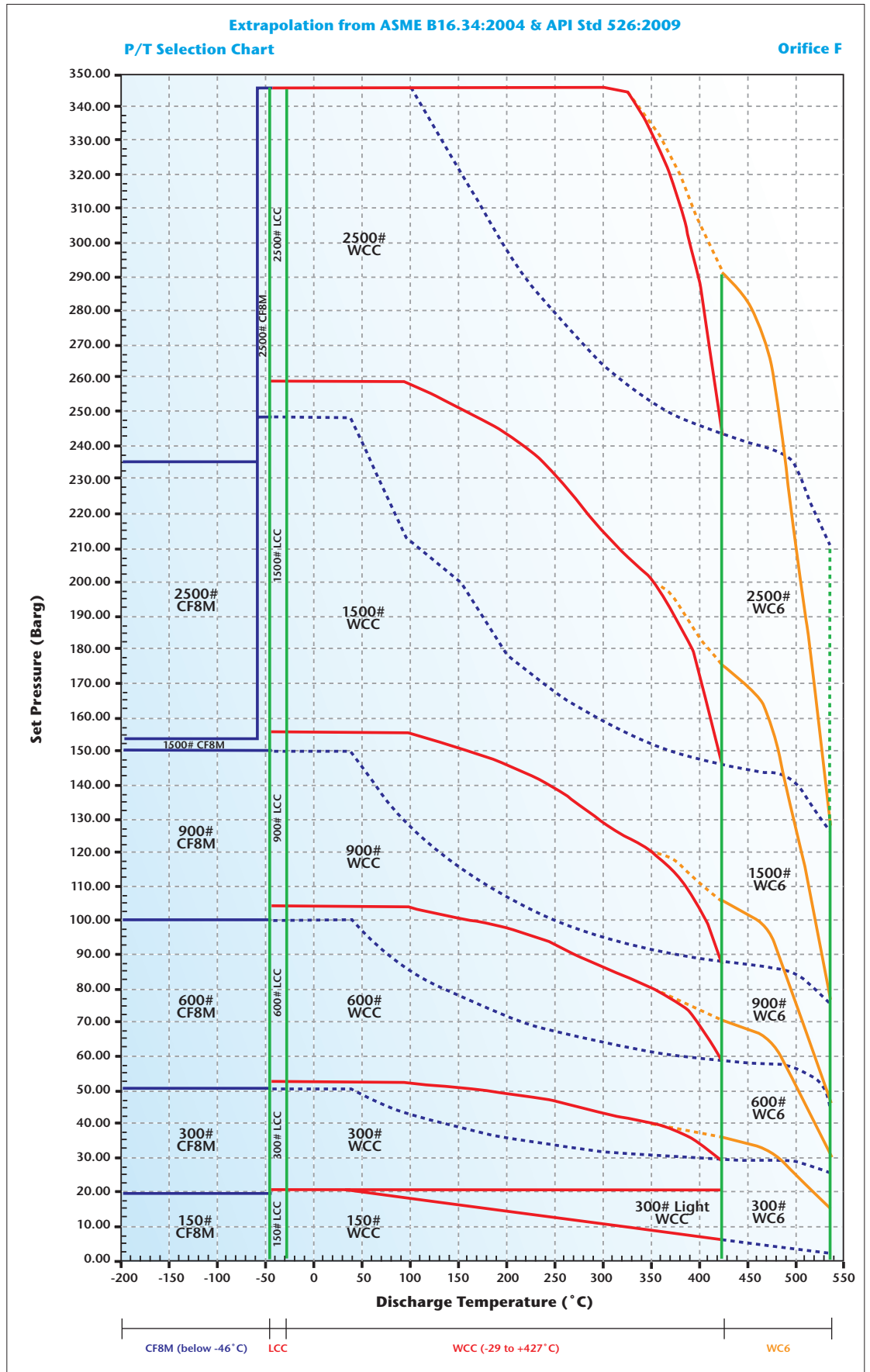

ORIFICE : G
3.24 cm²
0.503 in²

Starflow P Series Selection Table
According to API Std 526 : (edition 2009)

INLETx ORIFICEx OUTLET	ANSI FLANGE RATING		Model Number	Conventional	Bellows	Steam service	MAX. SET PRESSURE barg (psig)					MAX. BACK PRESSURE (1) barg (psig)		Body	Spring	
	Inlet	Outlet					-268°C to -47°C (-450°F to -51°F)	-46°C to -29°C (-50°F to -21°F)	-29°C to +38°C (-20°F to 100°F)	<232°C (<450°F)	<427°C (<800°F)	<538°C (<1000°F)	Conventional			Bellows
1½ G 3 (4)	150	150	P73G1	330	430	530			19.8 (285)	13 (185)	5.5 (80)		19.8 (285)	16 (230)	SA 216 Gr. WCC	Alloy Steel
1½ G 3 (4)	300	150	P73G7	330	430	530			19.8 (285)	19.8 (285)	19.8 (285)		19.8 (285)	16 (230)		
1½ G 3 (4)	300	150	P73G2	330	430	530			51 (745)	42.4 (615)	29 (410)		19.8 (285)	16 (230)		
1½ G 3 (4)	600	150	P73G3	330	430	530			102 (1440)	85 (1235)	58 (825)		19.8 (285)	16 (230)		
1½ G 3 (4)	900	300	P73G4	330	430	530			153 (2220)	127 (1845)	85 (1235)		51 (740)	32 (470)		
2 G 3	1500	300	P23G5	330	430	530			255 (3705)	212 (3080)	144 (2060)		51 (740)	32 (470)		
2 G 3	2500	300	P23G6	330	430	530			255 (3705)	255 (3705)	240 (3430)		51 (740)	32 (470)		
1½ G 3 (4)	300	150	P73G2	332	432	502					35 (510)	15 (225)	19.8 (285)	16 (230)	SA 216 Gr. WC6	High Temp. Alloy Steel
1½ G 3 (4)	600	150	P73G3	332	432	502					70 (1015)	31 (445)	19.8 (285)	16 (230)		
1½ G 3 (4)	900	300	P73G4	332	432	502					105 (1525)	46 (670)	51 (740)	34 (500)		
2 G 3	1500	300	P23G5	332	432	502					175 (2540)	77 (1115)	51 (740)	34 (500)		
2 G 3	2500	300	P23G6	332	432	502					255 (3705)	128 (1860)	51 (740)	34 (500)		
1½ G 3 (4)	150	150	P73G1	319	419				19.8 (285)				19.8 (285)	16 (230)	SA 352 Gr. LCC	Alloy Steel
1½ G 3 (4)	300	150	P73G7	319	419				19.8 (285)				19.8 (285)	16 (230)		
1½ G 3 (4)	300	150	P73G2	319	419				51 (745)				19.8 (285)	16 (230)		
1½ G 3 (4)	600	150	P73G3	319	419				102 (1440)				19.8 (285)	16 (230)		
1½ G 3 (4)	900	300	P73G4	319	419				153 (2220)				51 (740)	32 (470)		
2 G 3	1500	300	P23G5	319	419				255 (3705)				51 (740)	32 (470)		
2 G 3	2500	300	P23G6	319	419				255 (3705)				51 (740)	32 (470)		
1½ G 3 (4)	150	150	P73G1	316	416				19 (275)				19 (275)	16 (230)	SA 351 Gr. CF8M	Stainless Steel
1½ G 3 (4)	300	150	P73G7	316	416				19 (275)				19 (275)	16 (230)		
1½ G 3 (4)	300	150	P73G2	316	416				50 (720)				19 (275)	16 (230)		
1½ G 3 (4)	600	150	P73G3	316	416				99 (1440)				19 (275)	16 (230)		
1½ G 3 (4)	900	300	P73G4	316	416				110 (1600)				50 (720)	34 (500)		
2 G 3	1500	300	P23G5	316	416				169 (2450)				50 (720)	34 (500)		
2 G 3	2500	300	P23G6	316	416				179 (2600)				50 (720)	34 (500)		

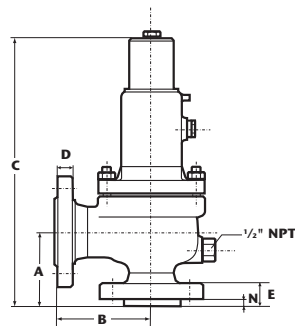

INLETx ORIFICEx OUTLET	ANSI FLANGE RATING Inlet Outlet	MODEL NUMBER	A(2) mm (in)	B(2) mm (in)	C mm (in)	D mm (in)	E mm (in)	N mm (in)	Approximate weight (3) kg (lbs)
1½ G 3 (4)	150 150	P73G1	123.8 (4-7/8)	120.7 (4-3/4)	455 (18)	23.9 (15/16)	31 (1-1/4)	12 (1/2)	22 (48)
1½ G 3 (4)	300 150	P73G7	123.8 (4-7/8)	120.7 (4-3/4)	455 (18)	23.9 (15/16)	34 (1-1/8)	12 (1/2)	23 (51)
1½ G 3 (4)	300 150	P73G2	123.8 (4-7/8)	152.4 (6)	455 (18)	23.9 (15/16)	36 (1-3/8)	12 (1/2)	25 (55)
1½ G 3 (4)	600 150	P73G3	123.8 (4-7/8)	152.4 (6)	455 (18)	23.9 (15/16)	36 (1-3/8)	12 (1/2)	26 (57)
1½ G 3 (4)	900 300	P73G4	123.8 (4-7/8)	165.1 (6-1/2)	505 (20)	28.4 (1-1/4)	46 (1-13/16)	13 (1/2)	42 (93)
2 G 3	1500 300	P23G5	155.6 (6-1/8)	171.5 (6-3/4)	570 (23)	28.4 (1-1/4)	51 (2)	16 (5/8)	55 (121)
2 G 3	2500 300	P23G6	155.6 (6-1/8)	171.5 (6-3/4)	570 (23)	28.4 (1-1/4)	67 (2-3/8)	16 (5/8)	61 (134)

- (1) Max. back pressure limits at 38°C; for higher temp. refer to ASME B16.5 flange ratings for conventional valves
- (2) Tolerances for A and B : ± 1.6 mm (± 1/16 in)
- (3) Valves with lifting lever : add 10%
- (4) 2½" outlet flange on request in conformity with API Std 526 ed. 84, model becomes P75G

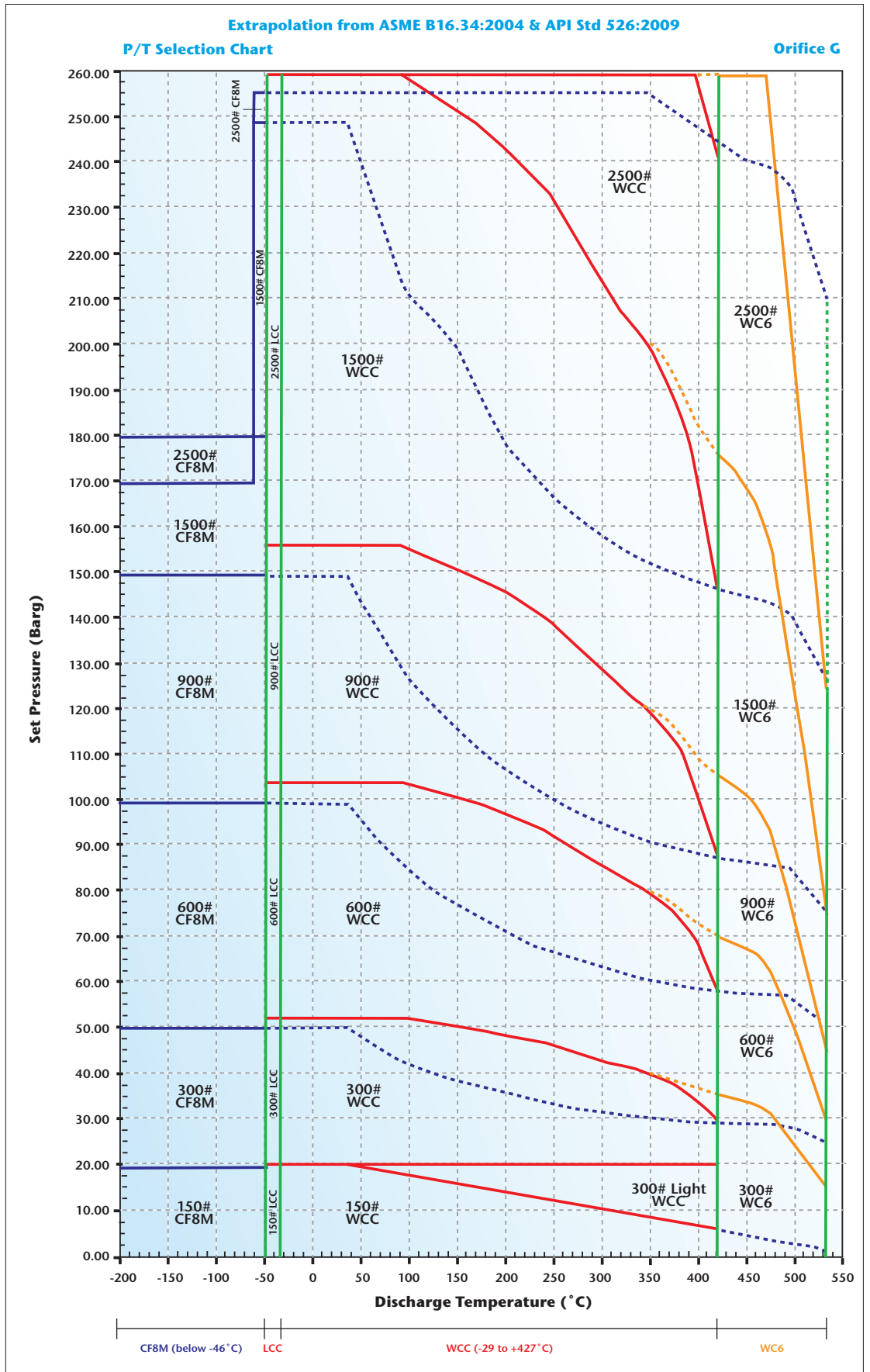

ORIFICE : H
5.06 cm²
0.785 in²

Starflow P Series Selection Table
 According to API Std 526 : (edition 2009)

INLETx ORIFICEx OUTLET	ANSI FLANGE RATING		Model Number	Conventional	Bellows	Steam service	MAX. SET PRESSURE barg (psig)					MAX. BACK PRESSURE (1) barg (psig)		MATERIALS		
	Inlet	Outlet					to -268°C (-450°F to -51°F)	to -46°C (-50°F to -21°F)	-29°C (-20°F to 100°F)	<232°C (<450°F)	<427°C (<800°F)	<538°C (<1000°F)	Conventional	Bellows	Body	Spring
1 1/2 H 3	150	150	P73H1	330	430	530			19.8 (285)	13 (185)	5.5 (80)		19.8 (285)	16 (230)	SA 216 Gr. WCC	Alloy Steel
1 1/2 H 3	300	150	P73H7	330	430	530			19.8 (285)	19.8 (285)	19.8 (285)		19.8 (285)	16 (230)		
2 H 3	300	150	P23H2	330	430	530			51 (740)	42.4 (615)	29 (410)		19.8 (285)	16 (230)		
2 H 3	600	150	P23H3	330	430	530			102 (1480)	85 (1235)	58 (825)		19.8 (285)	16 (230)		
2 H 3	900	150	P23H4	330	430	530			153 (2220)	127 (1845)	85 (1235)		19.8 (285)	16 (230)		
2 H 3	1500	300	P23H5	330	430	530			190 (2750)	190 (2750)	144 (2060)		51 (740)	29 (415)		
2 H 3	300	150	P23H2	332	432	502					35 (510)	15 (225)	19.8 (285)	16 (230)	SA 216 Gr. WC6	High Temp. Alloy Steel
2 H 3	600	150	P23H3	332	432	502					56 (815)	31 (445)	19.8 (285)	16 (230)		
2 H 3	900	150	P23H4	332	432	502					84 (1225)	46 (670)	19.8 (285)	16 (230)		
2 H 3	1500	300	P23H5	332	432	502					141 (2040)	77 (1115)	51 (740)	29 (415)		
1 1/2 H 3	150	150	P73H1	319	419			19.8 (285)					19.8 (285)	16 (230)	SA 352 Gr. LCC	Alloy Steel
1 1/2 H 3	300	150	P73H7	319	419			19.8 (285)					19.8 (285)	16 (230)		
2 H 3	300	150	P23H2	319	419			51 (740)					19.8 (285)	16 (230)		
2 H 3	600	150	P23H3	319	419			102 (1480)					19.8 (285)	16 (230)		
2 H 3	900	150	P23H4	319	419			153 (2220)					19.8 (285)	16 (230)		
2 H 3	1500	300	P23H5	319	419			190 (2750)					51 (740)	29 (415)		
1 1/2 H 3	150	150	P73H1	316	416		19 (275)						19 (275)	16 (230)	SA 351 Gr. CF8M	Stainless Steel
1 1/2 H 3	300	150	P73H7	316	416		19 (275)						19 (275)	16 (230)		
2 H 3	300	150	P23H2	316	416		50 (720)						19 (275)	16 (230)		
2 H 3	600	150	P23H3	316	416		99 (1440)						19 (275)	16 (230)		
2 H 3	900	150	P23H4	316	416		102 (1485)						19 (275)	16 (230)		
2 H 3	1500	300	P23H5	316	416		110 (1600)						29 (415)	29 (415)		

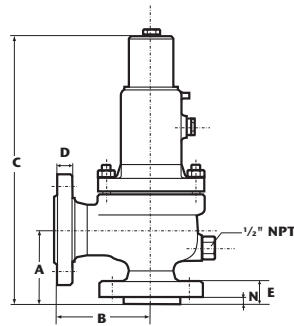

INLETx ORIFICEx OUTLET	ANSI FLANGE RATING		MODEL NUMBER	A(2) mm (in)	B(2) mm (in)	C mm (in)	D mm (in)	E mm (in)	N mm (in)	Approximate weight (3) kg (lbs)
1 1/2 H 3	150	150	P73H1	130.2 (5-1/8)	123.8 (4-7/8)	460 (18)	23.9 (1-1/8)	33 (1-3/8)	14 (1/2)	23 (51)
1 1/2 H 3	300	150	P73H7	130.2 (5-1/8)	123.8 (4-7/8)	460 (18)	23.9 (1-1/8)	36 (1-3/8)	14 (1/2)	25 (55)
2 H 3	300	150	P23H2	130.2 (5-1/8)	123.8 (4-7/8)	460 (18)	23.9 (1-1/8)	38 (1-1/2)	14 (1/2)	27 (60)
2 H 3	600	150	P23H3	154 (6-1/8)	161.9 (6-3/8)	515 (20)	23.9 (1-1/8)	41 (1-7/8)	14 (1/2)	38 (84)
2 H 3	900	150	P23H4	154 (6-1/8)	161.9 (6-3/8)	570 (22-1/2)	23.9 (1-1/8)	55 (2-1/8)	14 (1/2)	51 (112)
2 H 3	1500	300	P23H5	154 (6-1/8)	161.9 (6-3/8)	570 (22-1/2)	28.4 (1-1/8)	55 (2-1/8)	14 (1/2)	55 (121)

- (1) Max. back pressure limits at 38°C; for higher temp. refer to ASME B16.5 flange ratings for conventional valves
- (2) Tolerances for A and B : ± 1.6 mm (± 1/16 in)
- (3) Valves with lifting lever : add 10%

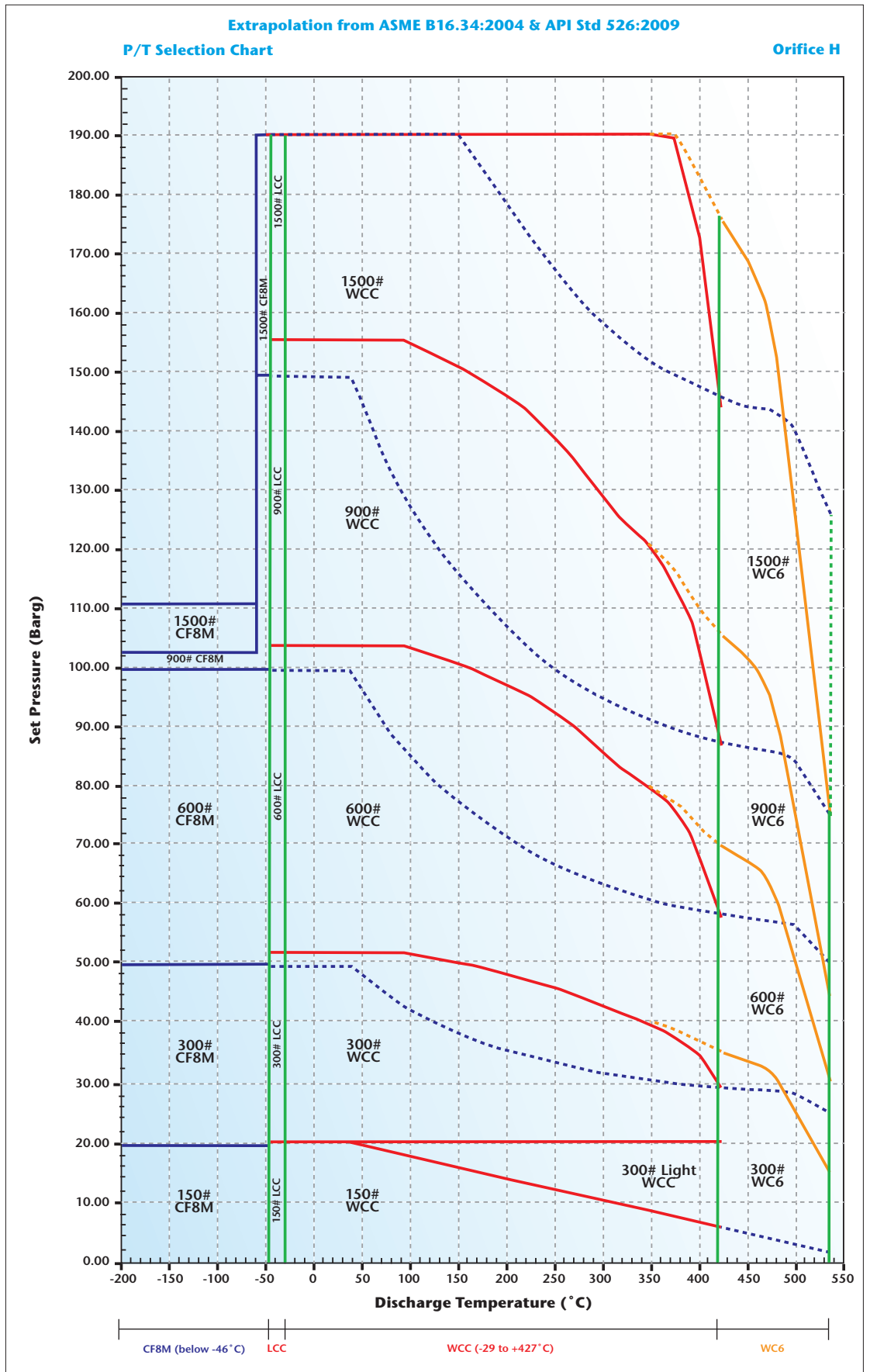

ORIFICE : J
8.30 cm²
1.287 in²

Starflow P Series Selection Table
 According to API Std 526 : (edition 2009)

INLETx ORIFICEx OUTLET	ANSI FLANGE RATING		Model Number	Conven-tional	Bellows	Steam service	MAX. SET PRESSURE barg (psig)					MAX. BACK PRESSURE (1) barg (psig)		Body	Spring	
	Inlet	Outlet					to -268°C (-47°F to -51°F)	to -46°C (-50°F to -21°F)	to -29°C (-20°F to 100°F)	<232°C (<450°F)	<427°C (<800°F)	<538°C (<1000°F)	Conven-tional			Bellows
2 J 3	150	150	P23J1	330	430	530			19.8 (285)	13 (185)	5.5 (80)		19.8 (285)	16 (230)		
2 J 3	300	150	P23J7	330	430	530			19.8 (285)	19.8 (285)	19.8 (285)		19.8 (285)	16 (230)		
3 J 4 (5)	300	150	P34J2	330	430	530			51 (740)	42.4 (615)	29 (410)		19.8 (285)	16 (230)	SA 216	Alloy Steel
3 J 4 (5)	600	150	P34J3	330	430	530			102 (1480)	85 (1235)	58 (825)		19.8 (285)	16 (230)	Gr. WCC	
3 J 4	900	150	P34J4	330	430	530			153 (2220)	127 (1845)	85 (1235)		19.8 (285)	16 (230)		
3 J 4	1500	300	P34J5	330	430	530			186 (2700)	186 (2700)	144 (2060)		41 (600)	16 (230)		
3 J 4 (5)	300	150	P34J2	332	432	502					35 (510)	15 (225)	19.8 (285)	16 (230)	SA 216	High Temp. Alloy Steel
3 J 4 (5)	600	150	P34J3	332	432	502					56 (815)	31 (445)	19.8 (285)	16 (230)	Gr. WC6	
3 J 4	900	150	P34J4	332	432	502					84 (1225)	46 (670)	19.8 (285)	16 (230)		
3 J 4	1500	300	P34J5	332	432	502					141 (2040)	77 (1115)	41 (600)	16 (230)		
2 J 3	150	150	P23J1	319	419			19.8 (285)					19.8 (285)	16 (230)		
2 J 3	300	150	P23J7	319	419			19.8 (285)					19.8 (285)	16 (230)		
3 J 4 (5)	300	150	P34J2	319	419			51 (740)					19.8 (285)	16 (230)	SA 352	Alloy Steel
3 J 4 (5)	600	150	P34J3	319	419			102 (1480)					19.8 (285)	16 (230)	Gr. LCC	
3 J 4	900	150	P34J4	319	419			153 (2220)					19.8 (285)	16 (230)		
3 J 4	1500	300	P34J5	319	419			186 (2700)					41 (600)	16 (230)		
2 J 3	150	150	P23J1	316	416		19 (275)						19 (275)	16 (230)		
2 J 3	300	150	P23J7	316	416		19 (275)						19 (275)	16 (230)		
3 J 4 (5)	300	150	P34J2	316	416		34 (500)						19 (275)	16 (230)	SA 351	Stainless Steel
3 J 4 (5)	600	150	P34J3	316	416		43 (625)						19 (275)	16 (230)	Gr. CF8M	
3 J 4	900	150	P34J4	316	416		55 (800)						19 (275)	16 (230)		
3 J 4	1500	300	P34J5	316	416		55 (800)						41 (600)	16 (230)		

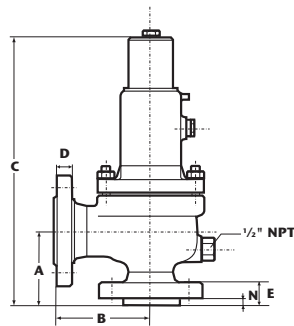

INLETx ORIFICEx OUTLET	ANSI FLANGE RATING		MODEL NUMBER	A(2) mm (in)	B(2) mm (in)	C mm (in)	D mm (in)	E mm (in)	N mm (in)	Approximate weight (3) kg (lbs)
2 J 3	150	150	P23J1	136.5 (5-3/8)	123.8 (4-7/8)	515 (20)	23.9 (1-1/8)	33 (1-3/8)	14 (1/2)	33 (73)
2 J 3	300	150	P23J7	136.5 (5-3/8)	123.8 (4-7/8)	515 (20)	23.9 (1-1/8)	38 (1-1/2)	14 (1/2)	35 (77)
3 J 4 (5)	300	150	P34J2	184.1 (7-3/8)	181 (7-1/8)	550 (22)	23.9 (1-1/8)	44 (1-3/4)	14 (1/2)	49 (108)
3 J 4 (5)	600	150	P34J3	184.1 (7-3/8)	181 (7-1/8)	590 (23)	23.9 (1-1/8)	47 (1-7/8)	14 (1/2)	60 (132)
3 J 4	900	150	P34J4	184.1 (7-3/8)	181 (7-1/8)	765 (30)	23.9 (1-1/8)	54 (2-1/8)	14 (1/2)	97 (213)
3 J 4	1500	300	P34J5	184.1 (7-3/8)	181 (7-1/8)	765 (30)	31.8 (1-1/4)	64 (2-1/2)	14 (1/2)	108 (238)

- (1) Max. back pressure limits at 38°C; for higher temp. refer to ASME B16.5 flange ratings for conventional valves
- (2) Tolerances for A and B : ± 1.6 mm (± 1/16 in)
- (3) Valves with lifting lever : add 10%
- (5) 2 1/2" inlet flange on request in conformity with API Std 526 ed. 84, model becomes P54J

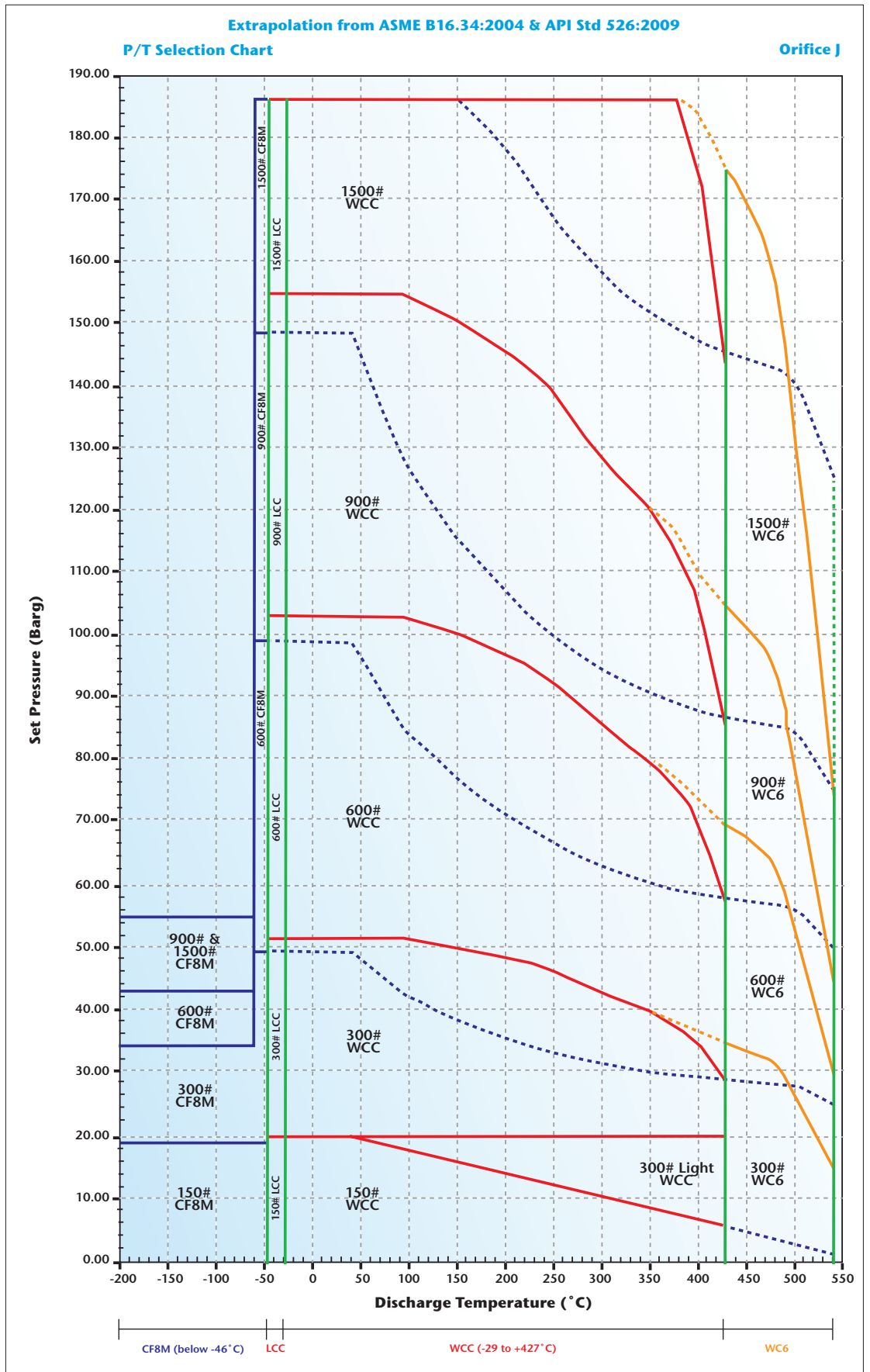

ORIFICE : K
11.86 cm²
1.838 in²

Starflow P Series Selection Table
 According to API Std 526 : (edition 2009)

INLETx ORIFICEx OUTLET	ANSI FLANGE RATING		Model Number	Conventional	Bellows	Steam service	MAX. SET PRESSURE barg (psig)					MAX. BACK PRESSURE (1) barg (psig)		Body	Spring	
	Inlet	Outlet					-268°C to -47°C (-450°F to -51°F)	-46°C to -29°C (-50°F to -21°F)	-29°C to +38°C (-20°F to 100°F)	<232°C (<450°F)	<427°C (<800°F)	<538°C (<1000°F)	Conventional			Bellows
3 K 4	150	150	P34K1	330	430	530			19.8 (285)	13 (185)	5.5 (80)		19.8 (285)	10 (150)	SA 216 Gr. WCC	Alloy Steel
3 K 4	300	150	P34K7	330	430	530			19.8 (285)	19.8 (285)	19.8 (285)		19.8 (285)	10 (150)		
3 K 4	300	150	P34K2	330	430	530			51 (740)	42.4 (615)	29 (410)		19.8 (285)	10 (150)		
3 K 4	600	150	P34K3	330	430	530			102 (1480)	85 (1235)	58 (825)		19.8 (285)	14 (200)		
3 K 6	900	150	P36K4	330	430	530			153 (2220)	127 (1845)	85 (1235)		19.8 (285)	14 (200)		
3 K 6	1500	300	P36K5	330	430	530			153 (2220)	153 (2220)	144 (2060)		41 (600)	14 (200)		
3 K 4	300	150	P34K2	332	432	502					35 (510)	15 (225)	19.8 (285)	10 (150)	SA 216 Gr. WC6	High Temp. Alloy Steel
3 K 4	600	150	P34K3	332	432	502					56 (815)	31 (445)	19.8 (285)	14 (200)		
3 K 6	900	150	P36K4	332	432	502					84 (1225)	46 (670)	19.8 (285)	14 (200)		
3 K 6	1500	300	P36K5	332	432	502					141 (2040)	77 (1115)	41 (600)	14 (200)		
3 K 4	150	150	P34K1	319	419			19.8 (285)					19.8 (285)	10 (150)	SA 352 Gr. LCC	Alloy Steel
3 K 4	300	150	P34K7	319	419			19.8 (285)					19.8 (285)	10 (150)		
3 K 4	300	150	P34K2	319	419			51 (740)					19.8 (285)	10 (150)		
3 K 4	600	150	P34K3	319	419			102 (1480)					19.8 (285)	14 (200)		
3 K 6	900	150	P36K4	319	419			153 (2220)					19.8 (285)	14 (200)		
3 K 6	1500	300	P36K5	319	419			153 (2220)					41 (600)	14 (200)		
3 K 4	150	150	P34K1	316	416		19 (275)						19 (275)	10 (150)	SA 351 Gr. CF8M	Stainless Steel
3 K 4	300	150	P34K7	316	416		19 (275)						19 (275)	10 (150)		
3 K 4	300	150	P34K2	316	416		36 (525)						19 (275)	10 (150)		
3 K 4	600	150	P34K3	316	416		41 (600)						19 (275)	14 (200)		
3 K 6	900	150	P36K4	316	416		41 (600)						19 (275)	14 (200)		
3 K 6	1500	300	P36K5	316	416		52 (750)						41 (600)	14 (200)		

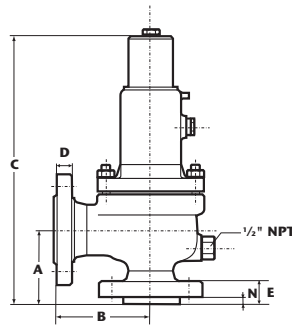

INLETx ORIFICEx OUTLET	ANSI FLANGE RATING		MODEL NUMBER	A(2) mm (in)	B(2) mm (in)	C mm (in)	D mm (in)	E mm (in)	N mm (in)	Approximate weight (3) kg (lbs)
3 K 4	150	150	P34K1	155.5 (6-1/8)	161.9 (6-3/8)	580 (23)	23.9 (15/16)	39 (1-1/4)	14 (9/16)	49 (108)
3 K 4	300	150	P34K7	155.5 (6-1/8)	161.9 (6-3/8)	580 (23)	23.9 (15/16)	45 (1-3/4)	14 (9/16)	54 (120)
3 K 4	300	150	P34K2	155.5 (6-1/8)	161.9 (6-3/8)	580 (23)	23.9 (15/16)	45 (1-3/4)	14 (9/16)	56 (123)
3 K 4	600	150	P34K3	184.1 (7-1/4)	181 (7-1/8)	635 (25)	23.9 (15/16)	47 (1-7/8)	14 (9/16)	68 (150)
3 K 6	900	150	P36K4	198.4 (7-13/16)	215.9 (8-1/2)	785 (31)	25.4 (1)	53 (2-1/16)	14 (9/16)	112 (247)
3 K 6	1500	300	P36K5	196.8 (7-3/4)	215.9 (8-1/2)	785 (31)	36.6 (1-7/16)	63 (2-7/16)	14 (9/16)	125 (275)

- (1) Max. back pressure limits at 38°C; for higher temp. refer to ASME B16.5 flange ratings for conventional valves
- (2) Tolerances for A and B : ± 1.6 mm (± 1/16 in)
- (3) Valves with lifting lever : add 10%

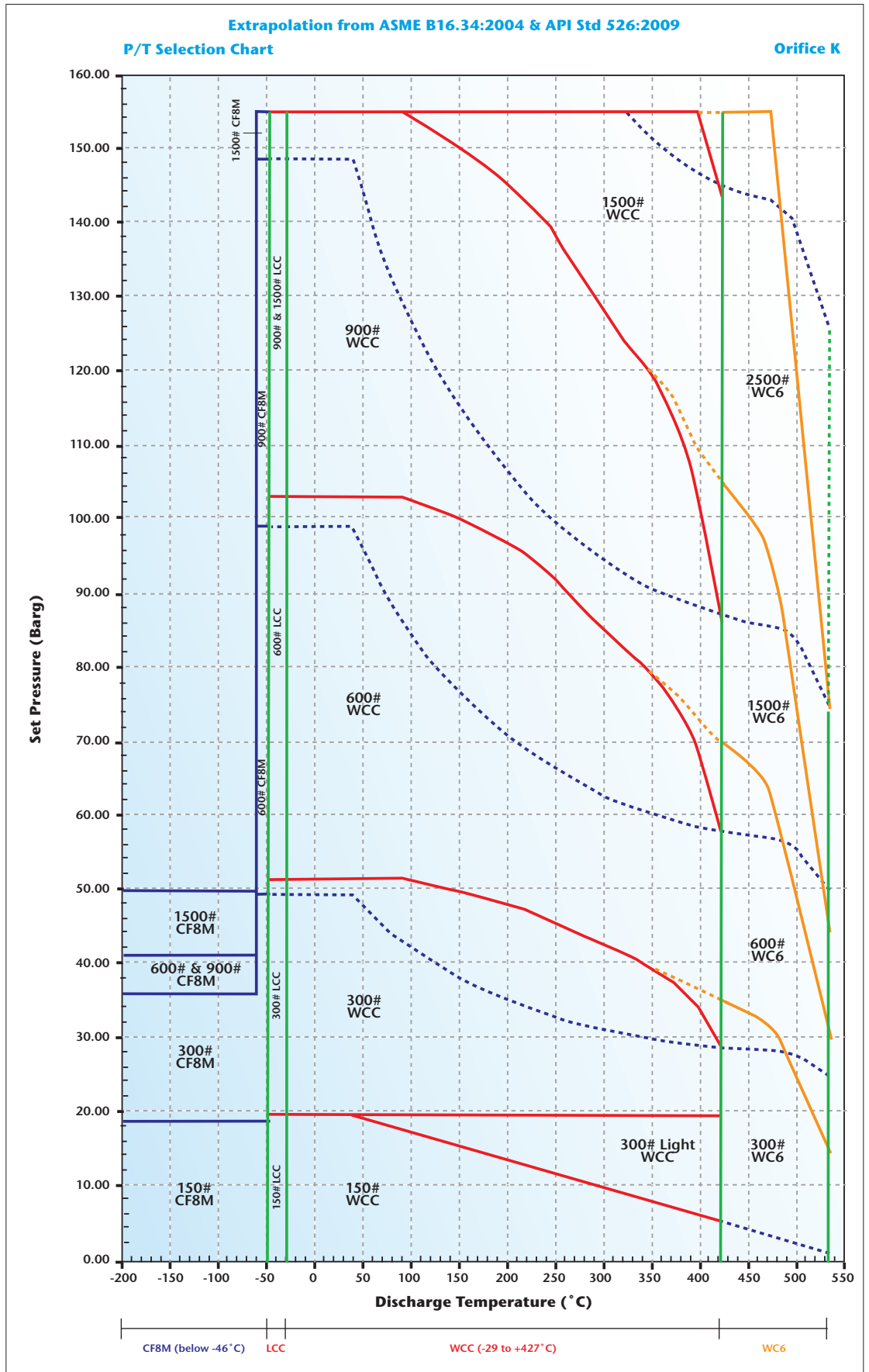

ORIFICE : L
18.41 cm²
2.853 in²

Starflow P Series Selection Table
According to API Std 526 : (edition 2009)

INLETx ORIFICEx OUTLET	ANSI FLANGE RATING		Model Number	Conven- tional	Bellows	Steam service	MAX. SET PRESSURE barg (psig)					MAX. BACK PRESSURE (1) barg (psig)		MATERIALS		
	Inlet	Outlet					-268°C to -47°C (-450°F to -51°F)	-46°C to -29°C (-50°F to -21°F)	-29°C to +38°C (-20°F to 100°F)	<232°C (<450°F)	<427°C (<800°F)	<538°C (<1000°F)	Conven- tional	Bellows	Body	Spring
3 L 4	150	150	P34L1	330	430	530			19.8 (285)	13 (185)	5.5 (80)		19.8 (285)	7 (100)		
3 L 4	300	150	P34L7	330	430	530			19.8 (285)	19.8 (285)	19.8 (285)		19.8 (285)	7 (100)		
4 L 6	300	150	P46L2	330	430	530			51 (740)	42.4 (615)	28 (410)		19.8 (285)	12 (170)	SA 216	Alloy Steel
4 L 6	600	150	P46L3	330	430	530			69 (1000)	69 (1000)	57 (825)		19.8 (285)	12 (170)	Gr. WCC	
4 L 6	900	150	P46L4	330	430	530			103 (1500)	103 (1500)	85 (1235)		19.8 (285)	12 (170)		
4 L 6	1500	150	P46L5	330	430	530				103 (1500)	103 (1500)		19.8 (285)	12 (170)		
4 L 6	300	150	P46L2	332	432	502					35 (510)	16 (225)	19.8 (285)	12 (170)	SA 216	High Temp. Alloy Steel
4 L 6	600	150	P46L3	332	432	502					69 (1000)	31 (445)	19.8 (285)	12 (170)	Gr. WC6	
4 L 6	900	150	P46L4	332	432	502					103 (1500)	46 (670)	19.8 (285)	12 (170)		
4 L 6	1500	150	P46L5	332	432	502					103 (1500)	76 (1115)	19.8 (285)	12 (170)		
3 L 4	150	150	P34L1	319	419				19.8 (285)				19.8 (285)	7 (100)		
3 L 4	300	150	P34L7	319	419				19.8 (285)				19.8 (285)	7 (100)	SA 352	Alloy Steel
4 L 6	300	150	P46L2	319	419				51 (740)				19.8 (285)	12 (170)	Gr. LCC	
4 L 6	600	150	P46L3	319	419				69 (1000)				19.8 (285)	12 (170)		
4 L 6	900	150	P46L4	319	419				103 (1500)				19.8 (285)	12 (170)		
3 L 4	150	150	P34L1	316	416		19 (275)						19 (275)	7 (100)		
3 L 4	300	150	P34L7	316	416		19 (275)						19 (275)	7 (100)	SA 351	Stainless Steel
4 L 6	300	150	P46L2	316	416		37 (535)						19 (275)	12 (170)	Gr. CF8M	
4 L 6	600	150	P46L3	316	416		37 (535)						19 (275)	12 (170)		
4 L 6	900	150	P46L4	316	416		48 (700)						19 (275)	12 (170)		

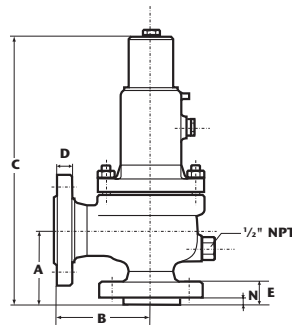

INLETx ORIFICEx OUTLET	ANSI FLANGE RATING		MODEL NUMBER	A(2) mm (in)	B(2) mm (in)	C mm (in)	D mm (in)	E mm (in)	N mm (in)	Approximate weight (3) kg (lbs)
3 L 4	150	150	P34L1	155.6 (6-1/8)	165.1 (6-1/2)	580 (23)	23.9 (1-13/16)	39 (1-1/2)	14 (1/2)	51 (112)
3 L 4	300	150	P34L7	155.6 (6-1/8)	165.1 (6-1/2)	580 (23)	23.9 (1-13/16)	45 (1-3/4)	14 (1/2)	57 (126)
4 L 6	300	150	P46L2	179.4 (7-1/16)	181 (7-1/8)	785 (31)	25.4 (1)	49 (1-13/16)	15.5 (5/8)	95 (210)
4 L 6	600	150	P46L3	179.4 (7-1/16)	203.2 (8)	845 (34)	25.4 (1)	56 (2-1/8)	15.5 (5/8)	115 (254)
4 L 6	900	150	P46L4	196.9 (7-3/4)	222.2 (8-3/4)	875 (35)	25.4 (1)	68 (2-11/16)	14.5 (1/2)	140 (310)
4 L 6	1500	150	P46L5	196.9 (7-3/4)	222.2 (8-3/4)	875 (35)	25.4 (1)	68 (2-11/16)	14.5 (1/2)	155 (342)

(1) Max. back pressure limits at 38°C; for higher temp. refer to ASME B16.5 flange ratings for conventional valves
 (2) Tolerances for A and B : ± 1.6 mm (±1/16 in)
 (3) Valves with lifting lever : add 10%

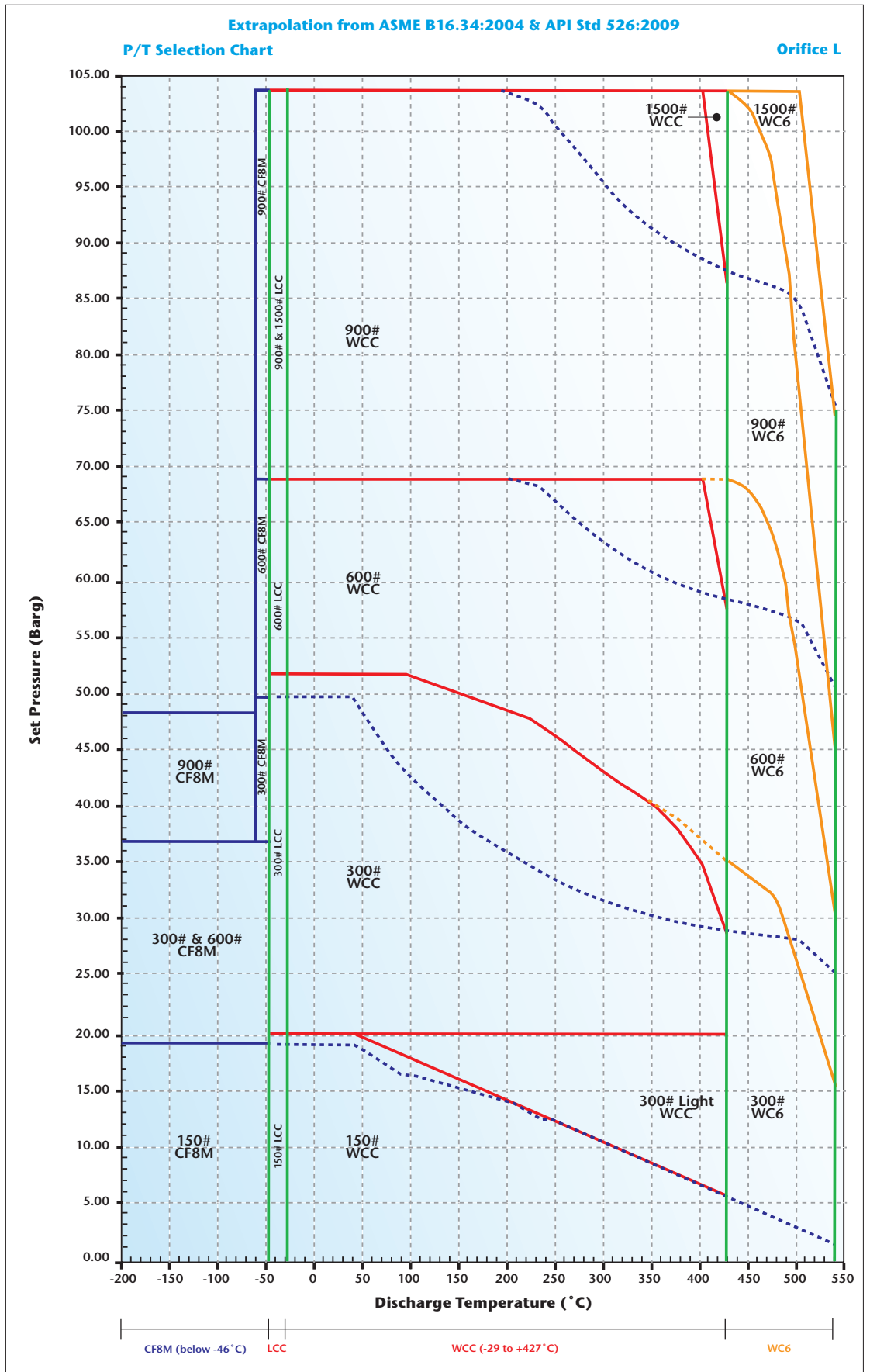

ORIFICE : M
23.2 cm²
3.60 in²

Starflow P Series Selection Table
 According to API Std 526 : (edition 2009)

INLETx ORIFICEx OUTLET	ANSI FLANGE RATING		Model Number	Conventional	Bellows	Steam service	MAX. SET PRESSURE barg (psig)					MAX. BACK PRESSURE (1) barg (psig)		MATERIALS		
	Inlet	Outlet					-268°C to -47°C (-450°F to -51°F)	-46°C to -29°C (-50°F to -21°F)	-29°C to +38°C (-20°F to 100°F)	<232°C (<450°F)	<427°C (<800°F)	<538°C (<1000°F)	Conventional	Bellows	Body	Spring
4 M 6	150	150	P46M1	330	430	530			19.8 (285)	13 (185)	5.5 (80)		19.8 (285)	5.5 (80)	SA 216 Gr. WCC	Alloy Steel
4 M 6	300	150	P46M7	330	430	530			19.8 (285)	19.8 (285)	19.8 (285)		19.8 (285)	5.5 (80)		
4 M 6	300	150	P46M2	330	430	530			51 (740)	42.4 (615)	28 (410)		19.8 (285)	11 (160)		
4 M 6	600	150	P46M3	330	430	530			76 (1100)	76 (1100)	57 (825)		19.8 (285)	11 (160)		
4 M 6	900	150	P46M4	330	430	530				76 (1100)	76 (1100)		19.8 (285)	11 (160)	SA 216 Gr. WC6	High Temp. Alloy Steel
4 M 6	300	150	P46M2	332	432	502					35 (510)	16 (225)	19.8 (285)	11 (160)		
4 M 6	600	150	P46M3	332	432	502					70 (1015)	31 (445)	19.8 (285)	11 (160)		
4 M 6	900	150	P46M4	332	432	502					76 (1100)	46 (670)	19.8 (285)	11 (160)		
4 M 6	150	150	P46M1	319	419			19.8 (285)					19.8 (285)	5.5 (80)	SA 352 Gr. LCC	Alloy Steel
4 M 6	300	150	P46M7	319	419			19.8 (285)					19.8 (285)	5.5 (80)		
4 M 6	300	150	P46M2	319	419			51 (740)					19.8 (285)	11 (160)		
4 M 6	600	150	P46M3	319	419			76 (1100)					19.8 (285)	11 (160)		
4 M 6	150	150	P46M1	316	416		19 (275)						19 (275)	5.5 (80)	SA 351 Gr. CF8M	Stainless Steel
4 M 6	300	150	P46M7	316	416		19 (275)						19 (275)	5.5 (80)		
4 M 6	300	150	P46M2	316	416		36 (525)						19 (275)	11 (160)		
4 M 6	600	150	P46M3	316	416		41 (600)						19 (275)	11 (160)		

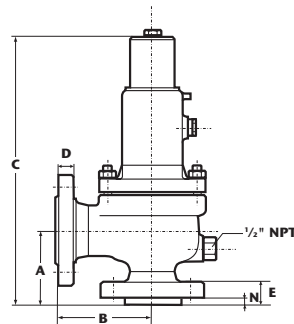

INLETx ORIFICEx OUTLET	ANSI FLANGE RATING		MODEL NUMBER	A(2)	B(2)	C	D	E	N	Approximate weight (3) kg (lbs)
	Inlet	Outlet		mm (in)	mm (in)	mm (in)	mm (in)	mm (in)	mm (in)	
4 M 6	150	150	P46M1	177.8 (7)	184.1 (7-1/4)	725 (29)	25.4 (1)	40 (1-1/8)	14 (1/2)	85 (187)
4 M 6	300	150	P46M7	177.8 (7)	184.1 (7-1/4)	725 (29)	25.4 (1)	48 (1-7/8)	14 (1/2)	88 (194)
4 M 6	300	150	P46M2	177.8 (7)	184.1 (7-1/4)	785 (31)	25.4 (1)	48 (1-7/8)	14 (1/2)	95 (210)
4 M 6	600	150	P46M3	177.8 (7)	203.2 (8)	845 (34)	25.4 (1)	54 (2-1/8)	14 (1/2)	115 (254)
4 M 6	900	150	P46M4	196.8 (7-3/4)	222.2 (8-3/4)	950 (38)	25.4 (1)	68 (2-1/4)	14 (1/2)	165 (364)

(1) Max. back pressure limits at 38°C; for higher temp. refer to ASME B16.5 flange ratings for conventional valves
 (2) Tolerances for A and B : ± 1.6 mm (± 1/16 in)
 (3) Valves with lifting lever : add 10%

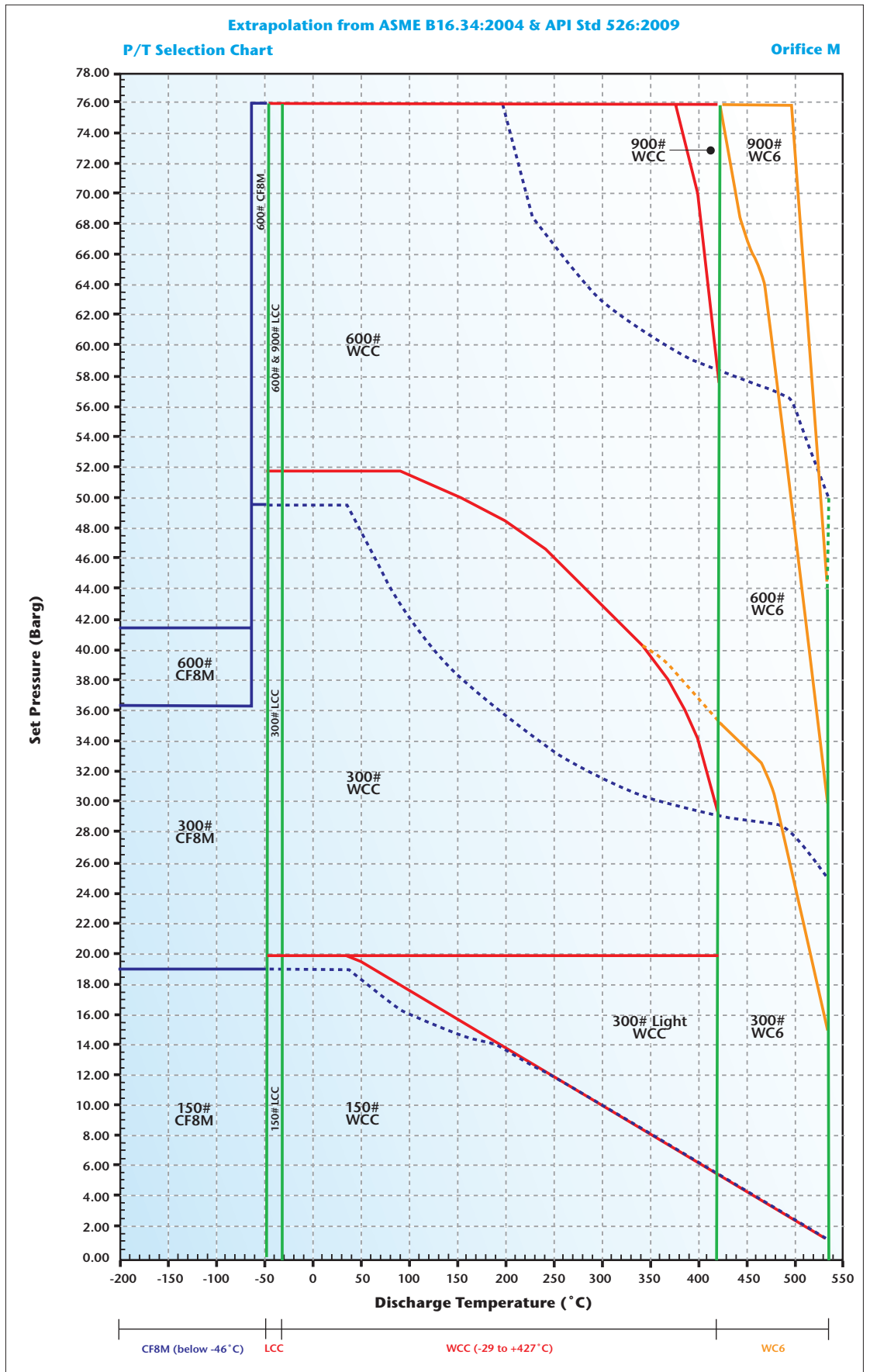

ORIFICE : N
28 cm²
4.34 in²

Starflow P Series Selection Table
According to API Std 526 : (edition 2009)

INLETx ORIFICEx OUTLET	ANSI FLANGE RATING		Model Number	Conven- tional	Bellows	Steam service	MAX. SET PRESSURE barg (psig)					MAX. BACK PRESSURE (1) barg (psig)		MATERIALS		
	Inlet	Outlet					-268°C to -47°C (-450°F to -51°F)	-46°C to -29°C (-50°F to -21°F)	-29°C to +38°C (-20°F to 100°F)	<232°C (<450°F)	<427°C (<800°F)	<538°C (<1000°F)	Conven- tional	Bellows	Body	Spring
4 N 6	150	150	P46N1	330	430	530			19.8 (285)	13 (185)	5.5 (80)		19.8 (285)	5.5 (80)	SA 216 Gr. WCC	Alloy Steel
4 N 6	300	150	P46N7	330	430	530			19.8 (285)	19.8 (285)	19.8 (285)		19.8 (285)	5.5 (80)		
4 N 6	300	150	P46N2	330	430	530			51 (740)	42.4 (615)	28 (410)		19.8 (285)	11 (160)		
4 N 6	600	150	P46N3	330	430	530			69 (1000)	69 (1000)	57 (825)		19.8 (285)	11 (160)		
4 N 6	900	150	P46N4	330	430	530				69 (1000)	69 (1000)		19.8 (285)	11 (160)	SA 216 Gr. WC6	High Temp. Alloy Steel
4 N 6	300	150	P46N2	332	432	502					35 (510)	16 (225)	19.8 (285)	11 (160)		
4 N 6	600	150	P46N3	332	432	502					69 (1000)	31 (445)	19.8 (285)	11 (160)		
4 N 6	900	150	P46N4	332	432	502					69 (1000)	46 (670)	19.8 (285)	11 (160)		
4 N 6	150	150	P46N1	319	419			19.8 (285)					19.8 (285)	5.5 (80)	SA 352 Gr. LCC	Alloy Steel
4 N 6	300	150	P46N7	319	419			19.8 (285)					19.8 (285)	5.5 (80)		
4 N 6	300	150	P46N2	319	419			51 (740)					19.8 (285)	11 (160)		
4 N 6	600	150	P46N3	319	419			69 (1000)					19.8 (285)	11 (160)		
4 N 6	150	150	P46N1	316	416		19 (275)						19 (275)	5.5 (80)	SA 351 Gr. CF8M	Stainless Steel
4 N 6	300	150	P46N7	316	416		19 (275)						19 (275)	5.5 (80)		
4 N 6	300	150	P46N2	316	416		31 (450)						19 (275)	11 (160)		
4 N 6	600	150	P46N3	316	416		34 (500)						19 (275)	11 (160)		

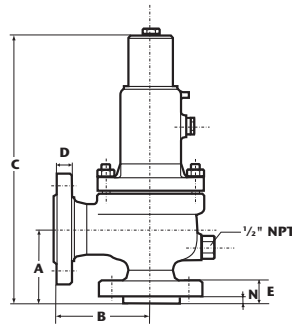

INLETx ORIFICEx OUTLET	ANSI FLANGE RATING		MODEL NUMBER	A(2) mm (in)	B(2) mm (in)	C mm (in)	D mm (in)	E mm (in)	N mm (in)	Approximate weight (3) kg (lbs)
4 N 6	150	150	P46N1	196.8 (7-3/4)	209.5 (8-1/4)	750 (30)	25.4 (1)	40 (1-3/16)	14 (9/16)	95 (210)
4 N 6	300	150	P46N7	196.8 (7-3/4)	209.5 (8-1/4)	750 (30)	25.4 (1)	48 (1-7/8)	14 (9/16)	100 (220)
4 N 6	300	150	P46N2	196.8 (7-3/4)	209.5 (8-1/4)	810 (32)	25.4 (1)	48 (1-7/8)	14 (9/16)	105 (232)
4 N 6	600	150	P46N3	196.8 (7-3/4)	222.2 (8-3/4)	870 (34)	25.4 (1)	54 (2-1/8)	14 (9/16)	125 (276)
4 N 6	900	150	P46N4	196.8 (7-3/4)	222.2 (8-3/4)	990 (39)	25.4 (1)	59 (2-3/16)	14 (9/16)	210 (460)

- (1) Max. back pressure limits at 38°C; for higher temp. refer to ASME B16.5 flange ratings for conventional valves
- (2) Tolerances for A and B : ± 1.6 mm (± 1/16 in)
- (3) Valves with lifting lever : add 10%

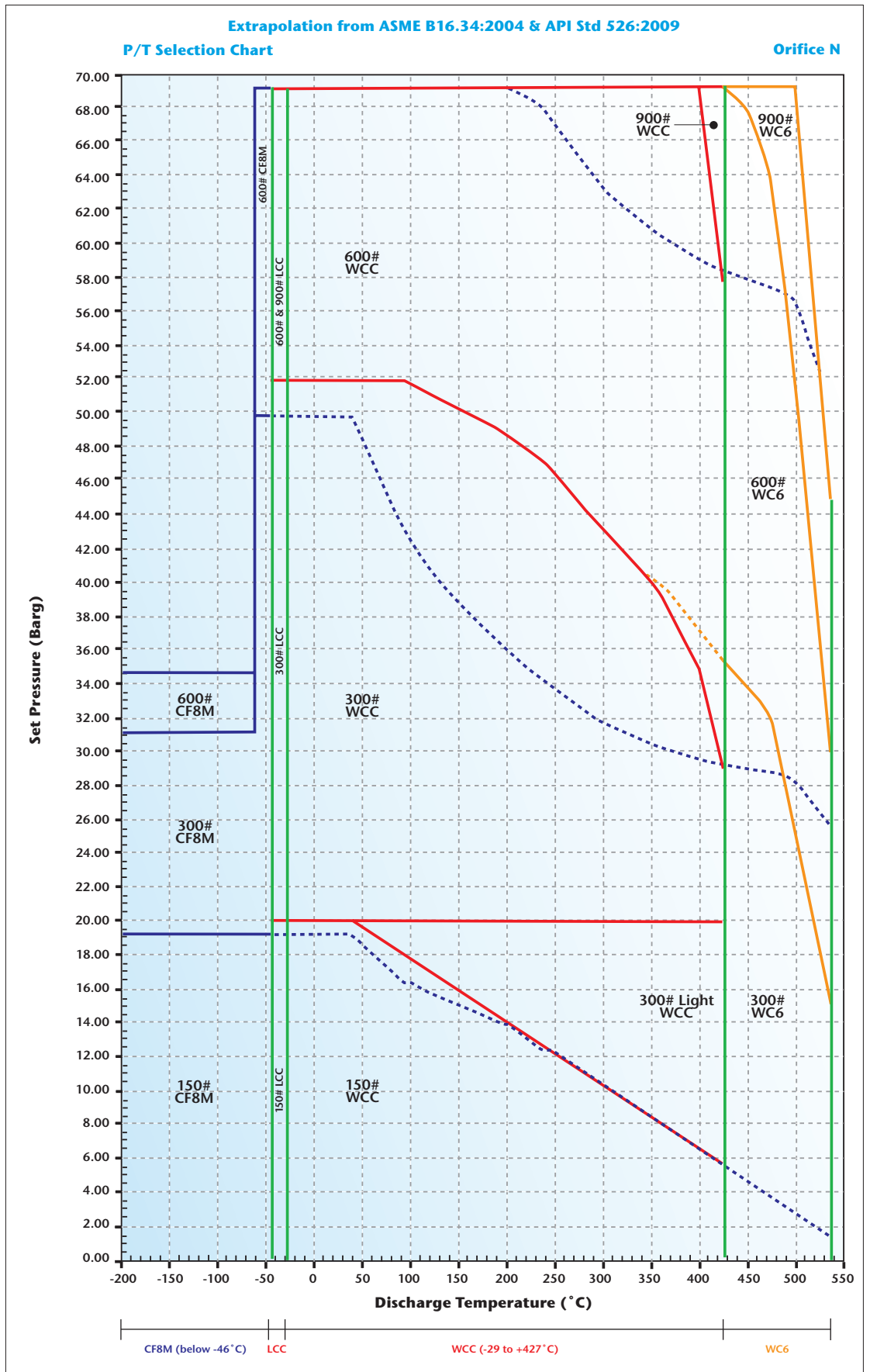

ORIFICE : P
41.2 cm²
6.38 in²

Starflow P Series Selection Table
According to API Std 526 : (edition 2009)

INLETx ORIFICEx OUTLET	ANSI FLANGE RATING		Model Number	Conventional	Bellows	Steam service	MAX. SET PRESSURE barg (psig)					MAX. BACK PRESSURE (1) barg (psig)		MATERIALS		
	Inlet	Outlet					-268°C to -47°C (-450°F to -51°F)	-46°C to -29°C (-50°F to -21°F)	-29°C to +38°C (-20°F to 100°F)	<232°C (<450°F)	<427°C (<800°F)	<538°C (<1000°F)	Conventional	Bellows	Body	Spring
4 P 6	150	150	P46P1	330	430	530			19.8 (285)	13 (185)	5.5 (80)		19.8 (285)	5.5 (80)	SA 216 Gr. WCC	Alloy Steel
4 P 6	300	150	P46P7	330	430	530			19.8 (285)	19.8 (285)	19.8 (285)		19.8 (285)	5.5 (80)		
4 P 6	300	150	P46P2	330	430	530			36.2 (525)	36.2 (525)	28 (410)		19.8 (285)	10 (150)		
4 P 6	600	150	P46P3	330	430	530			69 (1000)	69 (1000)	57 (825)		19.8 (285)	10 (150)		
4 P 6	900	150	P46P4	330	430	530				69 (1000)	69 (1000)		19.8 (285)	10 (150)	SA 216 Gr. WC6	High Temp. Alloy Steel
4 P 6	300	150	P46P2	332	432	502					35 (510)	16 (225)	19.8 (285)	10 (150)		
4 P 6	600	150	P46P3	332	432	502					69 (1000)	31 (445)	19.8 (285)	10 (150)		
4 P 6	900	150	P46P4	332	432	502					69 (1000)	46 (670)	19.8 (285)	10 (150)		
4 P 6	150	150	P46P1	319	419			19.8 (285)					19.8 (285)	5.5 (80)	SA 352 Gr. LCC	Alloy Steel
4 P 6	300	150	P46P7	319	419			19.8 (285)					19.8 (285)	5.5 (80)		
4 P 6	300	150	P46P2	319	419			36 (525)					19.8 (285)	10 (150)		
4 P 6	600	150	P46P3	319	419			69 (1000)					19.8 (285)	10 (150)		
4 P 6	150	150	P46P1	316	416		12 (175)						12 (175)	5.5 (80)	SA 351 Gr. CF8M	Stainless Steel
4 P 6	300	150	P46P7	316	416		12 (175)						12 (175)	5.5 (80)		
4 P 6	300	150	P46P2	316	416		21 (300)						19 (275)	10 (150)		
4 P 6	600	150	P46P3	316	416		33 (486)						19 (275)	10 (150)		

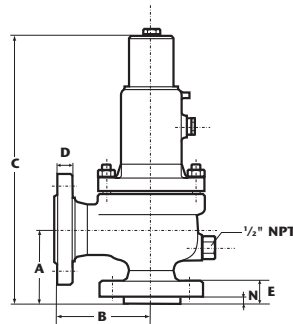

INLETx ORIFICEx OUTLET	ANSI FLANGE RATING Inlet	ANSI FLANGE RATING Outlet	MODEL NUMBER	A(2) mm (in)	B(2) mm (in)	C mm (in)	D mm (in)	E mm (in)	N mm (in)	Approximate weight (3) kg (lbs)
4 P 6	150	150	P46P1	181 (7-1/8)	228.6 (9)	795 (32)	25.4 (1)	40 (1-5/16)	14 (9/16)	105 (232)
4 P 6	300	150	P46P7	181 (7-1/8)	228.6 (9)	795 (32)	25.4 (1)	46 (1-13/16)	14 (9/16)	110 (242)
4 P 6	300	150	P46P2	225.4 (8-7/8)	254 (10)	850 (34)	25.4 (1)	48 (1-7/8)	14 (9/16)	125 (276)
4 P 6	600	150	P46P3	225.4 (8-7/8)	254 (10)	875 (35)	25.4 (1)	54 (2-1/8)	14 (9/16)	145 (320)
4 P 6	900	150	P46P4	225.4 (8-7/8)	254 (10)	1180 (47)	25.4 (1)	59 (2-3/8)	14 (9/16)	250 (550)

(1) Max. back pressure limits at 38°C; for higher temp. refer to ASME B16.5 flange ratings for conventional valves
 (2) Tolerances for A and B : ± 1.6 mm (± 1/16 in)
 (3) Valves with lifting lever : add 10%

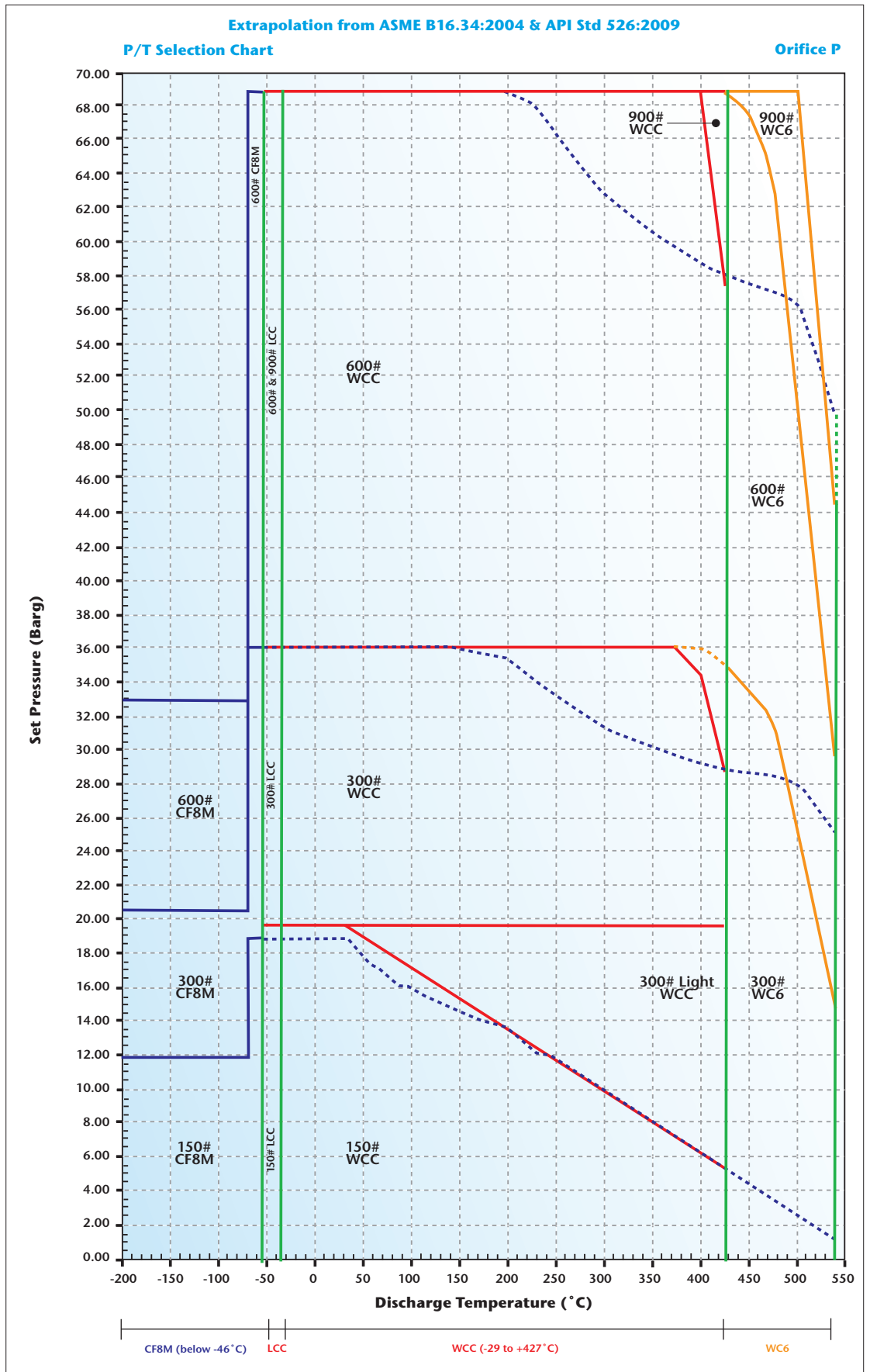

ORIFICE : Q
71.2 cm²
11.05 in²

Starflow P Series Selection Table
According to API Std 526 : (edition 2009)

INLETx ORIFICEx OUTLET	ANSI FLANGE RATING		Model Number	Conventional	Bellows	Steam service	MAX. SET PRESSURE barg (psig)					MAX. BACK PRESSURE (1) barg (psig)		MATERIALS		
	Inlet	Outlet					-268°C to -47°C (-450°F to -51°F)	-46°C to -29°C (-50°F to -21°F)	-29°C to +38°C (-20°F to 100°F)	<232°C (<450°F)	<427°C (<800°F)	<538°C (<1000°F)	Conventional	Bellows	Body	Spring
6 Q 8	150	150	P68Q1	330	430	530			11 (165)	11 (165)	5.5 (80)		8 (115)	5 (70)		
6 Q 8	300	150	P68Q7	330	430	530			11 (165)	11 (165)	11 (165)		8 (115)	5 (70)	SA 216	Alloy Steel
6 Q 8	300	150	P68Q2	330	430	530			21 (300)	21 (300)	21 (300)		8 (115)	8 (115)	Gr. WCC	Steel
6 Q 8	600	150	P68Q3	330	430	530			41 (600)	41 (600)	41 (600)		8 (115)	8 (115)		
6 Q 8	300	150	P68Q2	332	432	502					11 (165)	11 (165)	8 (115)	8 (115)	SA 216	High Temp. Alloy Steel
6 Q 8	600	150	P68Q3	332	432	502					41 (600)	31 (445)	8 (115)	8 (115)	Gr. WC6	
6 Q 8	150	150	P68Q1	319	419			11 (165)					8 (115)	5 (70)		
6 Q 8	300	150	P68Q7	319	419			11 (165)					8 (115)	5 (70)	SA 352	Alloy Steel
6 Q 8	300	150	P68Q2	319	419			21 (300)					8 (115)	8 (115)	Gr. LCC	Steel
6 Q 8	600	150	P68Q3	319	419			41 (600)					8 (115)	8 (115)		
6 Q 8	150	150	P68Q1	316	416		11 (165)						8 (115)	5 (70)		
6 Q 8	300	150	P68Q7	316	416		11 (165)						8 (115)	5 (70)	SA 351	Stainless Steel
6 Q 8	300	150	P68Q2	316	416		17 (250)						8 (115)	8 (115)	Gr. CF8M	Steel
6 Q 8	600	150	P68Q3	316	416		21 (300)						8 (115)	8 (115)		

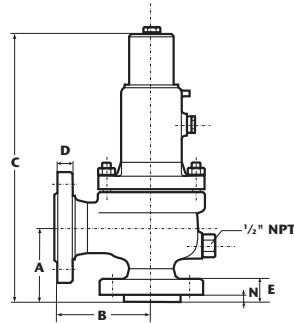

INLETx ORIFICEx OUTLET	ANSI FLANGE RATING		MODEL NUMBER	A(2) mm (in)	B(2) mm (in)	C mm (in)	D mm (in)	E mm (in)	N mm (in)	Approximate weight (3) kg (lbs)
6 Q 8	150	150	P68Q1	239.7 (9-2/16)	241.3 (9-1/2)	950 (38)	28.6 (1-1/4)	45 (1-3/4)	18 (11/16)	215 (474)
6 Q 8	300	150	P68Q7	239.7 (9-2/16)	241.3 (9-1/2)	950 (38)	28.6 (1-1/4)	57 (2-1/4)	18 (11/16)	230 (507)
6 Q 8	300	150	P68Q2	239.7 (9-2/16)	241.3 (9-1/2)	1070 (43)	28.6 (1-1/4)	57 (2-1/4)	18 (11/16)	255 (562)
6 Q 8	600	150	P68Q3	239.7 (9-2/16)	241.3 (9-1/2)	1140 (45)	28.6 (1-1/4)	68 (2-11/16)	18 (11/16)	305 (672)

(1) Max. back pressure limits at 38°C; for higher temp. refer to ASME B16.5 flange ratings for conventional valves
 (2) Tolerances for A and B : ± 3.2 mm (± 1/8 in)
 (3) Valves with lifting lever : add 10%

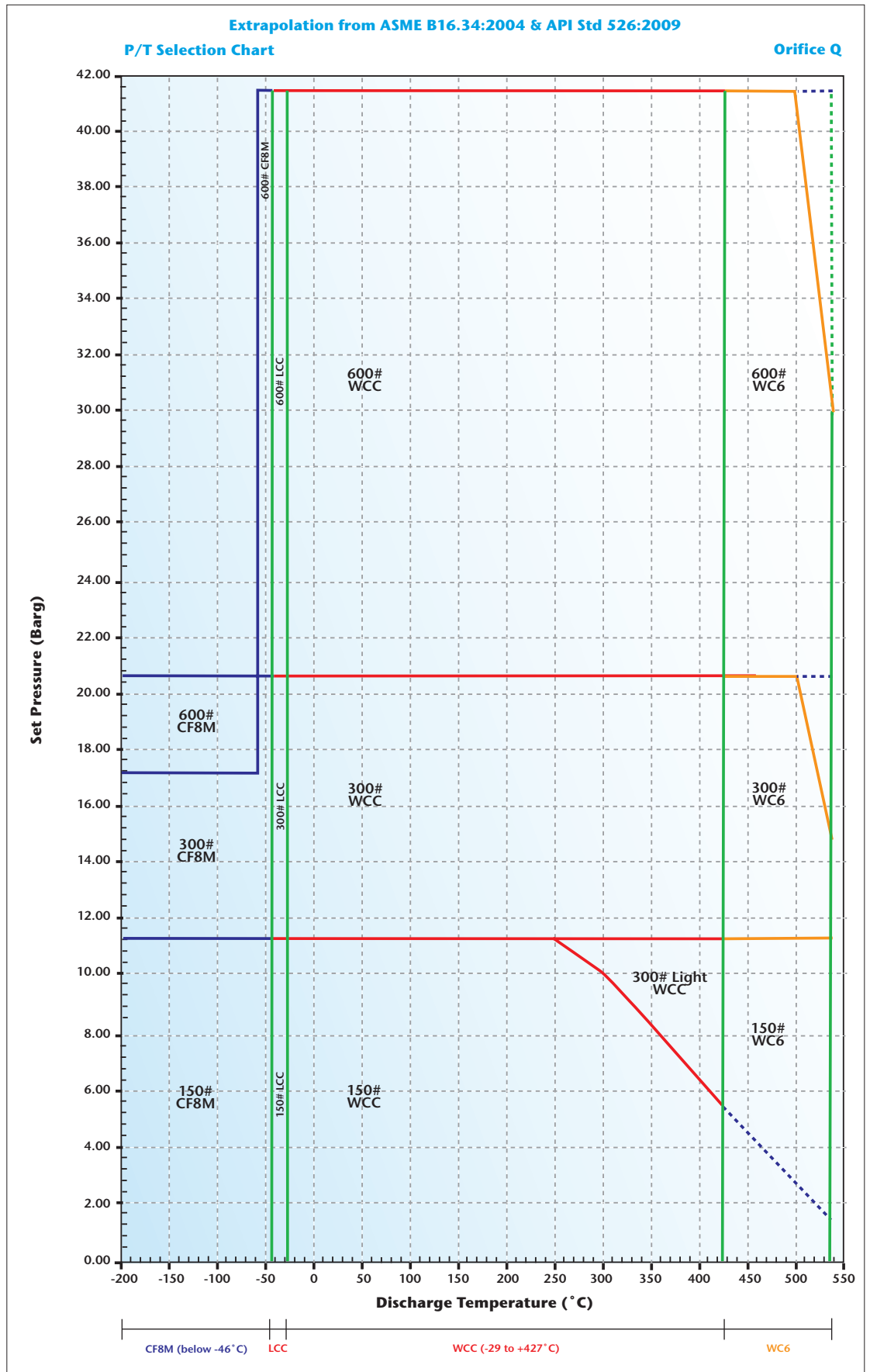

ORIFICE : R
103.2 cm²
16.00 in²

Starflow P Series Selection Table
According to API Std 526 : (edition 2009)

INLETx ORIFICEx OUTLET	ANSI FLANGE RATING		Model Number	Conventional	Bellows	Steam service	MAX. SET PRESSURE barg (psig)					MAX. BACK PRESSURE (1) barg (psig)		MATERIALS		
	Inlet	Outlet					-268°C to -47°C (-450°F to -51°F)	-46°C to -29°C (-50°F to -21°F)	-29°C to +38°C (-20°F to 100°F)	<232°C (<450°F)	<427°C (<800°F)	<538°C (<1000°F)	Conventional	Bellows	Body	Spring
6 R 8	150	150	P68R1	330	430	530			7 (100)	7 (100)	5.5 (80)		4 (60)	4 (60)		
6 R 8	300	150	P68R7	330	430	530			7 (100)	7 (100)	7 (100)		4 (60)	4 (60)	SA 216	Alloy Steel
6 R 10	300	150	P69R2	330	430	530			16 (230)	16 (230)	16 (230)		7 (100)	7 (100)	Gr. WCC	Steel
6 R 10	600	150	P69R3	330	430	530			21 (300)	21 (300)	21 (300)		7 (100)	7 (100)		
6 R 8	300	150	P69R2	332	432	502					7 (100)	7 (100)	4 (60)	4 (60)	SA 216	High Temp. Alloy Steel
6 R 10	600	150	P69R3	332	432	502					21 (300)	21 (300)	7 (100)	7 (100)	Gr. WC6	
6 R 8	150	150	P68R1	319	419			7 (100)					4 (60)	4 (60)		
6 R 8	300	150	P68R7	319	419			7 (100)					4 (60)	4 (60)	SA 352	Alloy Steel
6 R 10	300	150	P69R2	319	419			16 (230)					7 (100)	7 (100)	Gr. LCC	Steel
6 R 10	600	150	P69R3	319	419			21 (300)					7 (100)	7 (100)		
6 R 8	150	150	P68R1	316	416		3.8 (55)						3.8 (55)	3.8 (55)		
6 R 8	300	150	P68R7	316	416		3.8 (55)						3.8 (55)	3.8 (55)	SA 351	Stainless Steel
6 R 10	300	150	P69R2	316	416		10 (150)						7 (100)	7 (100)	Gr. CF8M	Steel
6 R 10	600	150	P69R3	316	416		14 (200)						7 (100)	7 (100)		

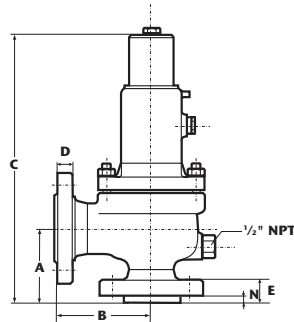

INLETx ORIFICEx OUTLET	ANSI FLANGE RATING		MODEL NUMBER	A(2) mm (in)	B(2) mm (in)	C mm (in)	D mm (in)	E mm (in)	N mm (in)	Approximate weight (3) kg (lbs)
6 R 8	150	150	P68R1	239.7 (9-2/16)	241.3 (9-1/2)	950 (38)	28.6 (1-1/4)	45 (1-3/4)	18 (1/2)	215 (474)
6 R 8	300	150	P68R7	239.7 (9-2/16)	241.3 (9-1/2)	950 (38)	28.6 (1-1/4)	57 (2-1/4)	18 (1/2)	230 (507)
6 R 10	300	150	P69R2	239.7 (9-2/16)	266.7 (10-1/2)	1070 (43)	30.2 (1-3/16)	57 (2-1/4)	18 (1/2)	275 (606)
6 R 10	600	150	P69R3	239.7 (9-2/16)	266.7 (10-1/2)	1140 (45)	30.2 (1-3/16)	68 (2-11/16)	18 (1/2)	325 (716)

(1) Max. back pressure limits at 38°C; for higher temp. refer to ASME B16.5 flange ratings for conventional valves
 (2) Tolerances for A and B : ± 3.2 mm (± 1/8 in)
 (3) Valves with lifting lever : add 10%

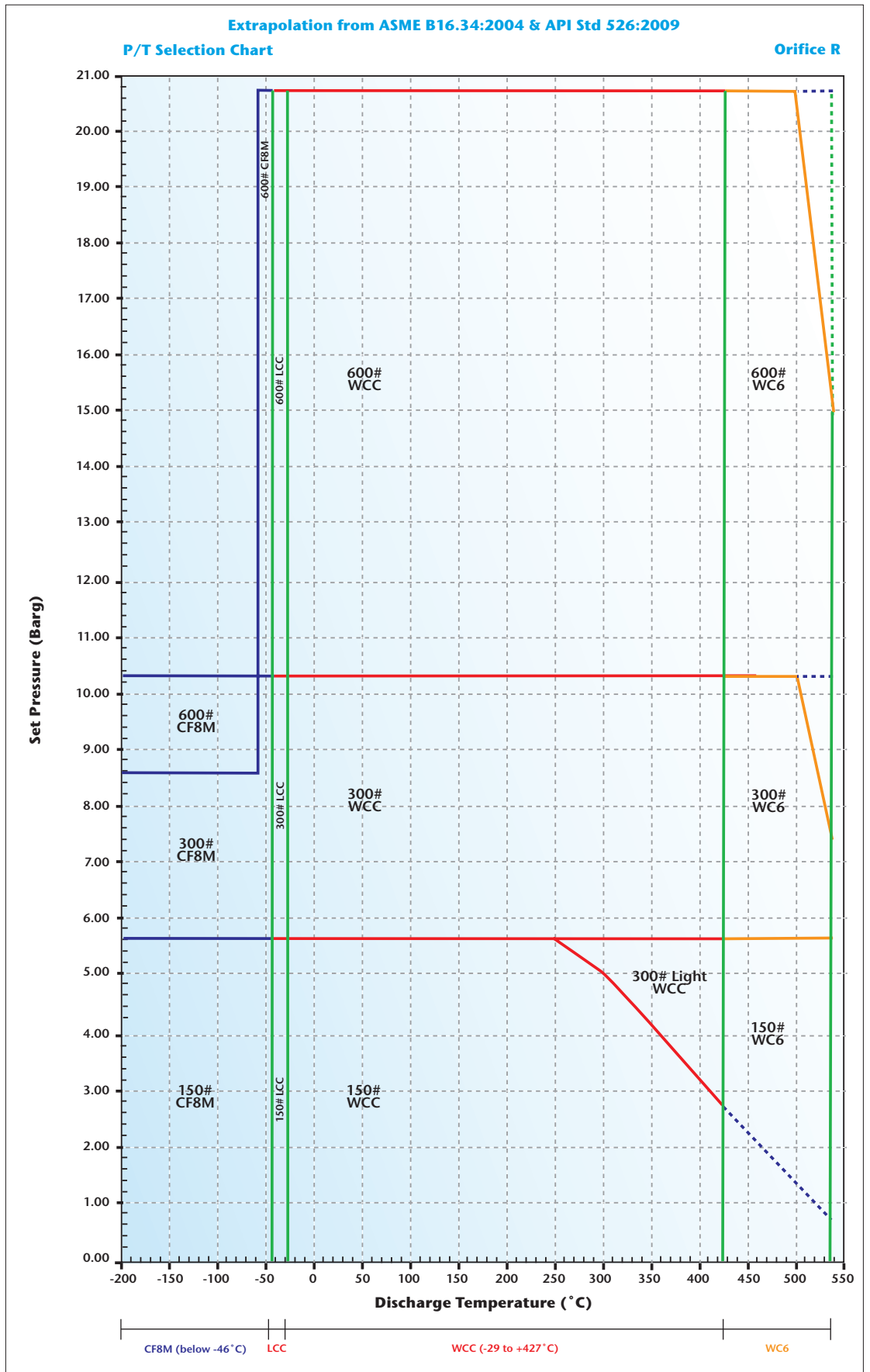

ORIFICE : T
168 cm²
26.00 in²

Starflow P Series Selection Table
According to API 526 : (edition 2009)

INLETx ORIFICEx OUTLET	ANSI FLANGE RATING		Model Number	Conventional	Bellows	Steam service	MAX. SET PRESSURE barg (psig)					MAX. BACK PRESSURE (1) barg (psig)		Body	Spring		
	Inlet	Outlet					-268°C to -47°C (-450°F to -51°F)	-46°C to -29°C (-50°F to -21°F)	-29°C to +38°C (-20°F to 100°F)	<232°C (<450°F)	<427°C (<800°F)	<538°C (<1000°F)	Conventional			Bellows	
8 T 10	150	150	P89T1	330	430	530			4.5 (65)	4.5 (65)	4.5 (65)		2 (30)	2 (30)	SA 216 Gr. WCC	Alloy Steel	
8 T 10	300	150	P89T7	330	430	530			4.5 (65)	4.5 (65)	4.5 (65)		2 (30)	2 (30)			
8 T 10	300	150	P89T2	330	430	530			8 (120)	8 (120)	8 (120)		4 (60)	4 (60)			
8 T 10	300	150	P89T3	330	430	530			21 (300)	21 (300)	21 (300)		7 (100)	7 (100)			
8 T 10	300	150	P89T2	332	432	502						8 (120)	8 (120)	4 (60)	4 (60)	SA 216 Gr. WC6	High Temp. Alloy Steel
8 T 10	300	150	P89T3	332	432	502						21 (300)	16 (225)	7 (100)	7 (100)		
8 T 10	150	150	P89T1	319	419			4.5 (65)					2 (30)	2 (30)	SA 352 Gr. LCC	Alloy Steel	
8 T 10	300	150	P89T7	319	419			4.5 (65)					2 (30)	2 (30)			
8 T 10	300	150	P89T2	319	419			8 (120)					4 (60)	4 (60)			
8 T 10	300	150	P89T3	319	419			21 (300)					7 (100)	7 (100)			
8 T 10	150	150	P89T1	316	416		3.5 (50)						2 (30)	2 (30)	SA 351 Gr. CF8M	Stainless Steel	
8 T 10	300	150	P89T7	316	416		3.5 (50)						2 (30)	2 (30)			
8 T 10	300	150	P89T2	316	416		4.5 (65)						4 (60)	4 (60)			

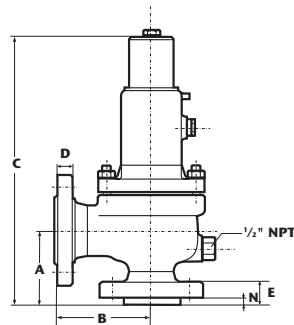

INLETx ORIFICEx OUTLET	ANSI FLANGE RATING		MODEL NUMBER	A(2) mm (in)	B(2) mm (in)	C mm (in)	D mm (in)	E mm (in)	N mm (in)	Approximate weight (3) kg (lbs)
8 T 10	150	150	P89T1	276.2 (10 ^{-7/8})	279.4 (11)	1020 (41)	30.2 (1 ^{-3/16})	49 (1 ^{-9/16})	18 (1 ^{1/8})	290 (640)
8 T 10	300	150	P89T7	276.2 (10 ^{-7/8})	279.4 (11)	1020 (41)	30.2 (1 ^{-3/16})	61 (2 ^{-3/8})	18 (1 ^{1/8})	310 (683)
8 T 10	300	150	P89T2	276.2 (10 ^{-7/8})	279.4 (11)	1200 (48)	30.2 (1 ^{-3/16})	61 (2 ^{-3/8})	18 (1 ^{1/8})	340 (749)
8 T 10	300	150	P89T3	276.2 (10 ^{-7/8})	279.4 (11)	1200 (48)	30.2 (1 ^{-3/16})	61 (2 ^{-3/8})	18 (1 ^{1/8})	350 (772)

(1) Max. back pressure limits at 38°C; for higher temp. refer to ASME B16.5 flange ratings for conventional valves
 (2) Tolerances for A and B : ± 3.2 mm (± 1/8 in)
 (3) Valves with lifting lever : add 10%

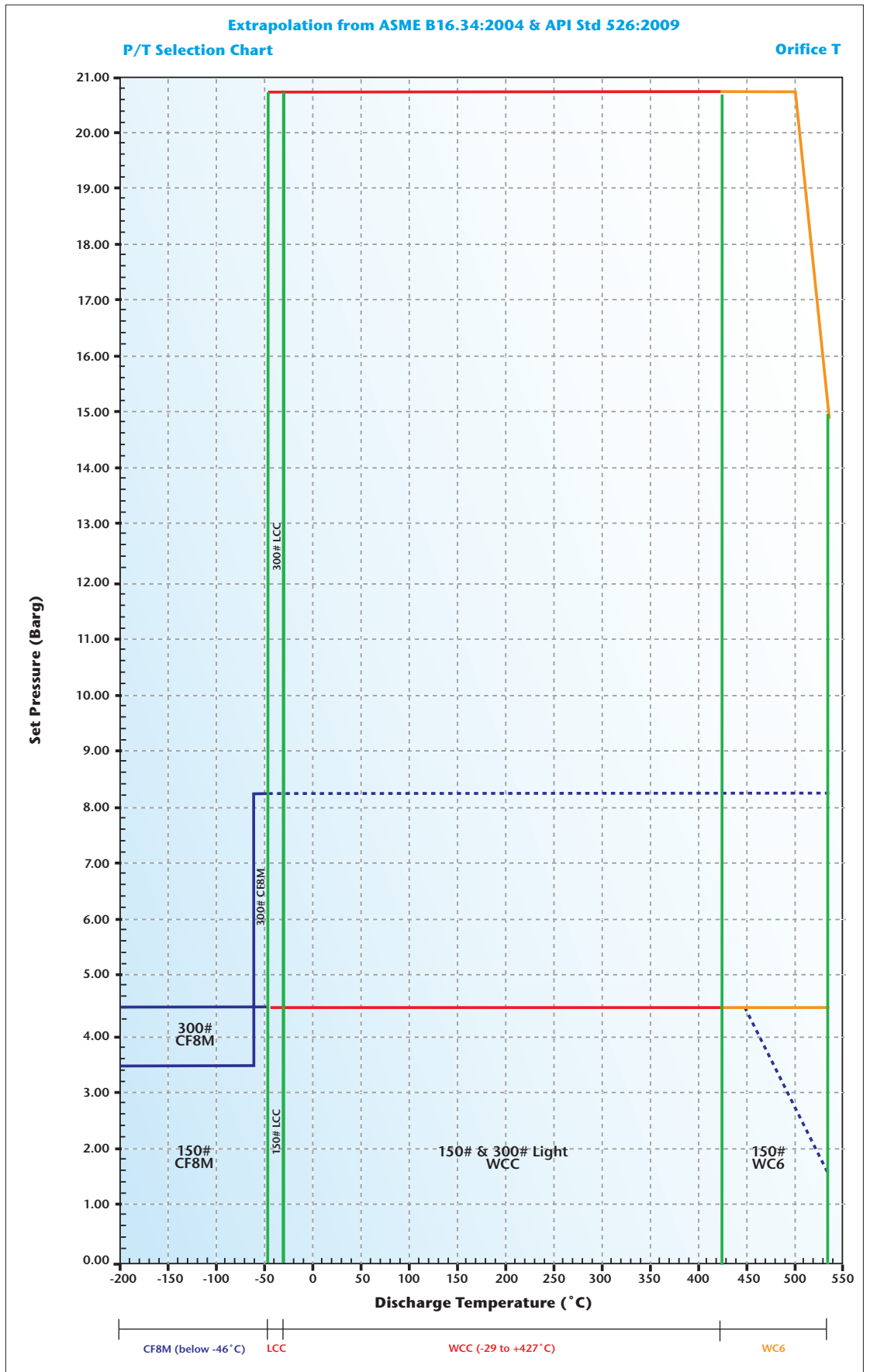

ORIFICE : V
301.6 cm² (actual)
46.75 in² (actual)

ORIFICE : W
452.3 cm² (actual)
70.10 in² (actual)

Starflow P Series Selection Table
 According to ASME B16.34

INLETx ORIFICEx OUTLET	ANSI FLANGE RATING		Model Number	Conven- tional	Bellows	Steam service	MAX. SET PRESSURE barg (psig)						MAX. BACK PRESSURE (1) barg (psig)		MATERIALS	
	Inlet	Outlet					-268°C to -47°C (-450°F to -51°F)	-46°C to -29°C (-50°F to -21°F)	-29°C to +38°C (-20°F to 100°F)	<232°C (<450°F)	<427°C (<800°F)	<538°C (<1000°F)	Conven- tional	Bellows	Body	Spring
10 V 14	150	150	P9BV1	330	430	530			7.1 (103)	7.1 (103)	5.5 (80)		2 (30)	3 (45)	SA 216 Gr. WCC	Alloy Steel
10 V 14	300	150	P9BV7	330	430	530			7.1 (103)	7.1 (103)	5.5 (80)		2 (30)	3 (45)		
10 V 14	300	150	P9BV2	330	430	530			20 (290)	20 (290)	20 (290)		4 (60)	3 (45)		
10 V 14	150	150	P9BV1	332	432	532					5.5 (80)	5.5 (80)	2 (30)	3 (45)	SA 216 Gr. WC6	High Temp. Alloy Steel
10 V 14	300	150	P9BV7	332	432	532					7.1 (103)	7.1 (103)	2 (30)	3 (45)		
10 V 14	300	150	P9BV2	332	432	532					20 (290)	20 (290)	4 (60)	3 (45)		
10 V 14	150	150	P9BV1	319	419			7.1 (103)					2 (30)	3 (45)	SA 352 Gr. LCC	Alloy Steel
10 V 14	300	150	P9BV7	319	419			7.1 (103)					2 (30)	3 (45)		
10 V 14	300	150	P9BV2	319	419			20 (290)					4 (60)	3 (45)		
10 V 14	150	150	P9BV1	316	416		7.1 (103)						2 (30)	3 (45)	SA 351 Gr. CF8M	Stainless Steel
10 V 14	300	150	P9BV7	316	416		7.1 (103)						2 (30)	3 (45)		
10 V 14	300	150	P9BV2	316	416		20 (290)						4 (60)	3 (45)		

12 W 12	150	150	PAAW1	330	430	530			6.3 (91)	6.3 (91)	5.5 (80)		2 (30)	2 (30)	SA 216 Gr. WCC	Alloy Steel
12 W 12	300	150	PAAW7	330	430	530			6.3 (91)	6.3 (91)	5.5 (80)		2 (30)	2 (30)		
12 W 12	300	150	PAAW2	330	430	530			20 (290)	20 (290)	20 (290)		4 (60)	4 (60)		
12 W 12	150	150	PAAW1	332	432	532					5.5 (80)	5.5 (80)	2 (30)	2 (30)	SA 216 Gr. WC6	High Temp. Alloy Steel
12 W 12	300	150	PAAW7	332	432	532					6.3 (91)	6.3 (91)	2 (30)	2 (30)		
12 W 12	300	150	PAAW2	332	432	532					20 (290)	20 (290)	4 (60)	4 (60)		
12 W 12	150	150	PAAW1	319	419			6.3 (91)					2 (30)	2 (30)	SA 352 Gr. LCC	Alloy Steel
12 W 12	300	150	PAAW7	319	419			6.3 (91)					2 (30)	2 (30)		
12 W 12	300	150	PAAW2	319	419			20 (290)					4 (60)	4 (60)		
12 W 12	150	150	PAAW1	316	416		6.3 (91)						2 (30)	2 (30)	SA 351 Gr. CF8M	Stainless Steel
12 W 12	300	150	PAAW7	316	416		6.3 (91)						2 (30)	2 (30)		
12 W 12	300	150	PAAW2	316	416								4 (60)	4 (60)		

Orifice V

Orifice W

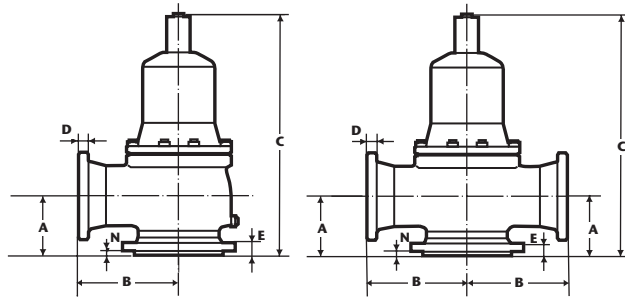

INLETx ORIFICEx OUTLET	ANSI FLANGE RATING		MODEL NUMBER	A(2) mm (in)	B(2) mm (in)	C mm (in)	D mm (in)	E mm (in)	N mm (in)	Approximate weight (3) kg (lbs)
10 V 14	150	150	P9BV1	380 (14- ¹⁵ / ₁₆)	370 (14- ⁵ / ₁₆)	1370 (53- ¹⁵ / ₁₆)	35 (1- ³ / ₈)	59 (2- ⁵ / ₁₆)	28 (1- ¹ / ₈)	470 (1080)
10 V 14	300	150	P9BV7	380 (14- ¹⁵ / ₁₆)	370 (14- ⁵ / ₁₆)	1370 (53- ¹⁵ / ₁₆)	35 (1- ³ / ₈)	77.5 (3- ¹ / ₁₆)	28 (1- ¹ / ₈)	530 (1215)
10 V 14	300	150	P9BV2	380 (14- ¹⁵ / ₁₆)	370 (14- ⁵ / ₁₆)	1620 (63- ³ / ₄)	35 (1- ³ / ₈)	77.5 (3- ¹ / ₁₆)	28 (1- ¹ / ₈)	780 (1790)

12 W 12	150	150	PAAW1	328 (12- ¹⁵ / ₁₆)	430 (16- ¹⁵ / ₁₆)	1375 (54- ¹ / ₈)	31.8 (1- ¹ / ₄)	61 (2- ³ / ₈)	28 (1- ¹ / ₈)	580 (1330)
12 W 12	300	150	PAAW7	328 (12- ¹⁵ / ₁₆)	430 (16- ¹⁵ / ₁₆)	1375 (54- ¹ / ₈)	39 (1- ³ / ₈)	82 (3- ¹ / ₄)	28 (1- ¹ / ₈)	650 (1330)
12 W 12	300	150	PAAW2	328 (12- ¹⁵ / ₁₆)	430 (16- ¹⁵ / ₁₆)	1650 (64- ¹⁵ / ₁₆)	39 (1- ³ / ₈)	82 (3- ¹ / ₄)	28 (1- ¹ / ₈)	830 (1900)

(2) Tolerances for A and B : ± 3.2 mm (± 1/8 in)
 (3) Valves with lifting lever : add 5%

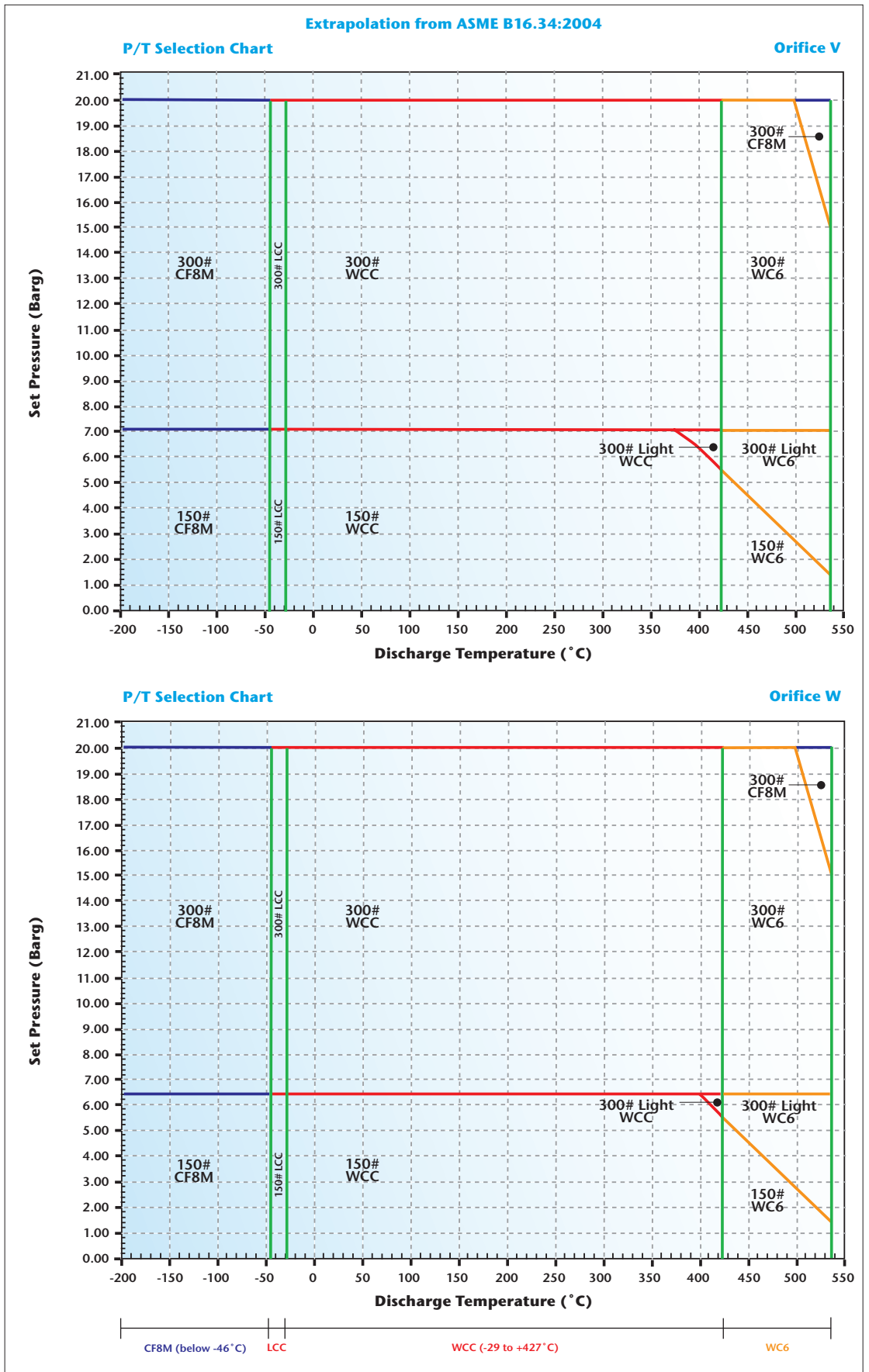

Starflow P Series Capacity Tables

Sizing a valve using capacity tables

For air, steam or water it can be quicker to size the valves using the capacity tables rather than the sizing formulas.

Example of sizing

Required flow : 5 800 Nm³/h of air
Set pressure : 42 bar
Overpressure : 10%

Using the air capacity table, with a set pressure of 42 bar, we find an orifice F (1.98 cm²), with a capacity of 6 193 Nm³/h.

This capacity includes the safety margin of 0.9. (as per ASME and ISO requirements).

Starflow P Series Capacity Tables

Air Calculation according to API STD 520 Capacities in Nm³/hr at 0 °C at 10% overpressure

Orifices cm ²	D	E	F	G	H	J	K	L	M	N	P	Q	R	T
	0.71	1.26	1.98	3.24	5.06	8.30	11.86	18.41	23.22	28	41.2	71.2	103.2	168
1	99	176	277	454	708	1162	1660	2577	3250	3920	5767	9967	14446	23517
1.5	125	222	349	572	893	1464	2092	3248	4096	4940	7269	12561	18207	29639
2	151	268	421	690	1077	1767	2524	3919	4943	5960	8770	15155	21967	35760
2.5	177	314	494	808	1261	2069	2957	4590	5789	6980	10271	17750	25727	41882
3	203	360	566	926	1446	2372	3389	5260	6635	8000	11772	20344	29488	48003
3.5	229	406	638	1044	1630	2674	3821	5931	7481	9021	13273	22938	33248	54124
4	255	452	710	1162	1815	2976	4253	6602	8327	10041	14775	25533	37008	60246
4.5	280	498	782	1280	1999	3279	4685	7273	9173	11061	16276	28127	40768	66367
5	306	544	854	1398	2183	3581	5117	7944	10019	12081	17777	30721	44529	72489
5.5	332	590	926	1516	2368	3884	5549	8614	10865	13102	19278	33316	48289	78610
6	358	635	999	1634	2552	4186	5982	9285	11711	14122	20779	35910	52049	84731
6.5	384	681	1071	1752	2736	4489	6414	9956	12557	15142	22281	38504	55810	90853
7	410	727	1143	1870	2921	4791	6846	10627	13403	16162	23782	41099	59570	96974
8	462	819	1287	2106	3290	5396	7710	11968	15095	18203	26784	46287	67090	109217
8.5	487	865	1359	2224	3474	5698	8142	12639	15941	19223	28285	48882	70851	115338
9	513	911	1431	2342	3658	6001	8574	13310	16787	20243	29787	51476	74611	121460
9.5	539	957	1504	2460	3843	6303	9007	13981	17634	21264	31288	54070	78371	127581
10	565	1003	1576	2579	4027	6606	9439	14652	18480	22284	32789	56664	82132	133703
11	617	1095	1720	2815	4396	7210	10303	15993	20172	24324	35791	61853	89652	145945
12	669	1186	1864	3051	4764	7815	11167	17335	21864	26365	38794	67042	97173	158188
13	720	1278	2009	3287	5133	8420	12032	18676	23556	28405	41796	72230	104693	170431
14	772	1370	2153	3523	5502	9025	12896	20018	25248	30446	44799	77419	112214	182674
15	824	1462	2297	3759	5871	9630	13760	21360	26940	32486	47801	82608	119735	194917
16	875	1554	2442	3995	6239	10235	14624	22701	28632	34527	50803	87796	127255	207160
18	979	1737	2730	4467	6977	11444	16353	25384	32017	38608	56808	98173	142296	231645
20	1082	1921	3019	4940	7714	12654	18082	28068	35401	42688	62813	108551	157338	256131
22	1186	2105	3307	5412	8452	13864	19810	30751	38785	46769	68818	118928		
24	1289	2288	3596	5884	9189	15073	21539	33434	42169	50850	74823	129305		
26	1393	2472	3884	6356	9927	16283	23267	36117	45554	54931	80827	139682		
28	1496	2656	4173	6829	10664	17493	24996	38801	48938	59012	86832	150060		
30	1600	2839	4462	7301	11402	18703	26724	41484	52322	63093	92837	160437		
32	1703	3023	4750	7773	12139	19912	28453	44167	55707	67174	98842	170814		
34	1807	3206	5039	8245	12877	21122	30182	46850	59091	71255	104847	181191		
36	1910	3390	5327	8717	13614	22332	31910	49533	62475	75336	110852	191569		
38	2014	3574	5616	9190	14352	23541	33639	52217	65859	79417	116856	201946		
40	2117	3757	5904	9662	15089	24751	35367	54900	69244	83498	122861	212323		
42	2221	3941	6193	10134	15827	25961	37096	57583	72628	87579	128866			
44	2324	4125	6482	10606	16564	27171	38824	60266	76012	91660	134871			
46	2428	4308	6770	11079	17302	28380	40553	62949	79396	95741	140876			
48	2531	4492	7059	11551	18039	29590	42282	65633	82781	99822	146880			
50	2635	4676	7347	12023	18777	30800	44010	68316	86165	103903	152885			
52	2738	4859	7636	12495	19514	32009	45739	70999	89549	107983	158890			
54	2842	5043	7925	12967	20252	33219	47467	73682	92933	112064	164895			
56	2945	5227	8213	13440	20989	34429	49196	76366	96318	116145	170900			
58	3049	5410	8502	13912	21727	35639	50924	79049	99702	120226	176904			
60	3152	5594	8790	14384	22464	36848	52653	81732	103086	124307	182909			
65	3411	6053	9512	15565	24308	39872	56974	88440	111547	134510	197921			
70	3669	6512	10233	16745	26152	42897	61296	95148	120008	144712	212933			
75	3928	6971	10955	17926	27995	45921	65617	101856	128468					
80	4187	7430	11676	19106	29839	48945	69939	108564	136929					
85	4446	7889	12398	20287	31683	51970	74260	115272						
90	4704	8348	13119	21467	33526	54994	78582	121980						
95	4963	8808	13840	22648	35370	58018	82903	128688						
100	5222	9267	14562	23829	37214	61042	87224	135396						
110	5739	10185	16005	26190	40901	67091	95867							
120	6257	11103	17448	28551	44589	73139	104510							
130	6774	12021	18891	30912	48276	79188	113153							
140	7291	12940	20334	33273	51963	85236	121796							
150	7809	13858	21776	35634	55651	91285	130439							
160	8326	14776	23219	37995	59338	97334								
170	8844	15694	24662	40356	63026	103382								
180	9361	16612	26105	42717	66713	109431								
190	9878	17531	27548	45079	70401	115479								
200	10396	18449	28991	47440										
220	11431	20285	31877	52162										
240	12465	22122	34763	56884										
260	13500	23958	37648	61606										
280	14535	25794	40534											
300	15570	27631	43420											
320	16605	29467	46306											
340	17639	31304	49192											
360	18674	33140	52077											
380	19709	34977												
400	20744	36813												
420	21779	38649												

Starflow P Series Capacity Tables

Saturated Steam Calculation according to API STD 520 Capacities T/hr at 10% overpressure

Orifices cm ²	D	E	F	G	H	J	K	L	M	N	P	Q	R	T
	0.71	1.26	1.98	3.24	5.06	8.30	11.86	18.41	23.22	28	41.2	71.2	103.2	168
Set pressure - barg														
1	0.08	0.14	0.21	0.35	0.55	0.90	1.28	1.99	2.51	3.02	4.45	7.69	11.14	18.13
1.5	0.10	0.17	0.27	0.44	0.69	1.13	1.61	2.50	3.16	3.81	5.60	9.69	14.04	22.85
2	0.12	0.21	0.32	0.53	0.83	1.36	1.95	3.02	3.81	4.60	6.76	11.69	16.94	27.57
2.5	0.14	0.24	0.38	0.62	0.97	1.60	2.28	3.54	4.46	5.38	7.92	13.69	19.84	32.29
3	0.16	0.28	0.44	0.71	1.11	1.83	2.61	4.06	5.12	6.17	9.08	15.69	22.74	37.01
3.5	0.18	0.31	0.49	0.80	1.26	2.06	2.95	4.57	5.77	6.96	10.23	17.69	25.64	41.73
4	0.20	0.35	0.55	0.90	1.40	2.30	3.28	5.09	6.42	7.74	11.39	19.69	28.54	46.45
4.5	0.22	0.38	0.60	0.99	1.54	2.53	3.61	5.61	7.07	8.53	12.55	21.69	31.44	51.17
5	0.24	0.42	0.66	1.08	1.68	2.76	3.95	6.13	7.73	9.32	13.71	23.69	34.34	55.89
5.5	0.26	0.45	0.71	1.17	1.83	2.99	4.28	6.64	8.38	10.10	14.86	25.69	37.23	60.61
6	0.28	0.49	0.77	1.26	1.97	3.23	4.61	7.16	9.03	10.89	16.02	27.69	40.13	65.33
6.5	0.30	0.53	0.83	1.35	2.11	3.46	4.95	7.68	9.68	11.68	17.18	29.69	43.03	70.05
7	0.32	0.56	0.88	1.44	2.25	3.69	5.28	8.19	10.33	12.46	18.34	31.69	45.93	74.77
8	0.36	0.63	0.99	1.62	2.54	4.16	5.95	9.23	11.64	14.04	20.65	35.69	51.73	84.21
8.5	0.38	0.67	1.05	1.72	2.68	4.39	6.28	9.75	12.29	14.82	21.81	37.69	54.63	88.93
9	0.40	0.70	1.10	1.81	2.82	4.63	6.61	10.26	12.94	15.61	22.97	39.69	57.53	93.65
9.5	0.42	0.74	1.16	1.90	2.96	4.86	6.94	10.78	13.60	16.40	24.13	41.69	60.43	98.37
10	0.44	0.77	1.22	1.99	3.11	5.09	7.28	11.30	14.25	17.18	25.28	43.69	63.33	103.09
11	0.48	0.84	1.33	2.17	3.39	5.56	7.94	12.33	15.55	18.76	27.60	47.69	69.13	112.54
12	0.52	0.91	1.44	2.35	3.67	6.03	8.61	13.37	16.86	20.33	29.91	51.69	74.93	121.98
13	0.56	0.99	1.55	2.53	3.96	6.49	9.28	14.40	18.16	21.90	32.23	55.70	80.73	131.42
14	0.60	1.06	1.66	2.72	4.24	6.96	9.94	15.44	19.47	23.48	34.54	59.70	86.53	140.86
15	0.64	1.13	1.77	2.90	4.53	7.43	10.61	16.47	20.77	25.05	36.86	63.70	92.32	150.30
16	0.68	1.20	1.88	3.08	4.81	7.89	11.28	17.50	22.08	26.62	39.17	67.70	98.12	159.74
18	0.75	1.34	2.11	3.44	5.38	8.82	12.61	19.57	24.69	29.77	43.80	75.70	109.72	178.62
20	0.83	1.48	2.33	3.81	5.95	9.76	13.94	21.64	27.30	32.92	48.43	83.70	121.32	197.50
22	0.91	1.62	2.55	4.17	6.52	10.69	15.28	23.71	29.91	36.06	53.06	91.70		
24	0.99	1.76	2.77	4.54	7.09	11.62	16.61	25.78	32.52	39.21	57.69	99.70		
26	1.07	1.91	3.00	4.90	7.65	12.56	17.94	27.85	35.13	42.36	62.32	107.71		
28	1.15	2.05	3.22	5.27	8.22	13.49	19.27	29.92	37.73	45.50	66.95	115.71		
30	1.23	2.19	3.44	5.63	8.79	14.42	20.61	31.99	40.34	48.65	71.58	123.71		
32	1.31	2.33	3.66	5.99	9.36	15.35	21.94	34.06	42.95	51.80	76.21	131.71		
34	1.39	2.47	3.89	6.36	9.93	16.29	23.27	36.13	45.56	54.94	80.84	139.71		
36	1.47	2.61	4.11	6.72	10.50	17.22	24.61	38.19	48.17	58.09	85.47	147.71		
38	1.55	2.76	4.33	7.09	11.07	18.15	25.94	40.26	50.78	61.24	90.11	155.72		
40	1.63	2.90	4.55	7.45	11.63	19.09	27.27	42.33	53.39	64.38	94.74	163.72		
42	1.71	3.04	4.78	7.81	12.20	20.02	28.60	44.40	56.00	67.53	99.37			
44	1.79	3.18	5.00	8.18	12.77	20.95	29.94	46.47	58.61	70.68	104.00			
46	1.87	3.32	5.22	8.54	13.34	21.88	31.27	48.54	61.22	73.82	108.63			
48	1.95	3.46	5.44	8.91	13.91	22.82	32.60	50.61	63.83	76.97	113.26			
50	2.03	3.61	5.67	9.27	14.48	23.75	33.94	52.68	66.44	80.12	117.89			
52	2.11	3.75	5.89	9.63	15.05	24.68	35.27	54.75	69.05	83.26	122.52			
54	2.19	3.89	6.11	10.00	15.62	25.61	36.60	56.81	71.66	86.41	127.15			
56	2.27	4.03	6.33	10.36	16.18	26.55	37.93	58.88	74.27	89.56	131.78			
58	2.35	4.17	6.56	10.73	16.75	27.48	39.27	60.95	76.88	92.70	136.41			
60	2.43	4.31	6.78	11.09	17.32	28.41	40.60	63.02	79.49	95.85	141.04			
65	2.63	4.67	7.33	12.00	18.74	30.74	43.93	68.19	86.01	103.72	152.61			
70	2.83	5.02	7.89	12.91	20.16	33.08	47.26	73.37	92.53	111.58	164.19			
75	3.03	5.38	8.45	13.82	21.59	35.41	50.60	78.54	99.06					
80	3.23	5.73	9.00	14.73	23.01	37.74	53.93	83.71	105.58					
85	3.43	6.08	9.56	15.64	24.43	40.07	57.26	88.88						
90	3.63	6.44	10.12	16.55	25.85	42.40	60.59	94.06						
95	3.83	6.79	10.67	17.46	27.27	44.74	63.92	99.23						
100	4.03	7.15	11.23	18.37	28.69	47.07	67.26	104.40						
110	4.43	7.85	12.34	20.19	31.54	51.73	73.92							
120	4.82	8.56	13.45	22.01	34.38	56.40	80.59							
130	5.22	9.27	14.57	23.84	37.22	61.06	87.25							
140	5.62	9.98	15.68	25.66	40.07	65.72	93.91							
150	6.02	10.69	16.79	27.48	42.91	70.39	100.58							
160	6.42	11.39	17.90	29.30	45.75	75.05								
170	6.82	12.10	19.02	31.12	48.60	79.72								
180	7.22	12.81	20.13	32.94	51.44	84.38								
190	7.62	13.52	21.24	34.76	54.28	89.04								
200	8.02	14.23	22.35	36.58										

Starflow P Series Capacity Tables

Water Calculation according to API STD 520 Capacities m³/hr at 10% overpressure

Orifices cm ²	D	E	F	G	H	J	K	L	M	N	P	Q	R	T
	0.71	1.26	1.98	3.24	5.06	8.30	11.86	18.41	23.22	28	41.2	71.2	103.2	168
Set pressure - barg														
1	2.66	4.73	7.4	12.2	19.0	31	44	69	87	105	155	267	387	630
1.5	3.26	5.79	9.1	14.9	23.2	38	54	85	107	129	189	327	474	772
2	3.77	6.68	10.5	17.2	26.8	44	63	98	123	149	219	378	547	891
2.5	4.21	7.47	11.7	19.2	30.0	49	70	109	138	166	244	422	612	996
3	4.61	8.19	12.9	21.1	32.9	54	77	120	151	182	268	463	670	1092
3.5	4.98	8.84	13.9	22.7	35.5	58	83	129	163	196	289	500	724	1179
4	5.33	9.45	14.9	24.3	38.0	62	89	138	174	210	309	534	774	1260
4.5	5.65	10.03	15.8	25.8	40.3	66	94	146	185	223	328	567	821	1337
5	5.96	10.57	16.6	27.2	42.4	70	99	154	195	235	346	597	866	1409
5.5	6.25	11.08	17.4	28.5	44.5	73	104	162	204	246	362	626	908	1478
6	6.52	11.58	18.2	29.8	46.5	76	109	169	213	257	379	654	948	1544
6.5	6.79	12.05	18.9	31.0	48.4	79	113	176	222	268	394	681	987	1607
7	7.05	12.50	19.7	32.2	50.2	82	118	183	230	278	409	707	1024	1667
8	7.53	13.37	21.0	34.4	53.7	88	126	195	246	297	437	755	1095	1782
8.5	7.76	13.78	21.7	35.4	55.3	91	130	201	254	306	451	779	1129	1837
9	7.99	14.18	22.3	36.5	56.9	93	133	207	261	315	464	801	1161	1891
9.5	8.21	14.57	22.9	37.5	58.5	96	137	213	268	324	476	823	1193	1942
10	8.42	14.95	23.5	38.4	60.0	98	141	218	275	332	489	845	1224	1993
11	8.83	15.68	24.6	40.3	63.0	103	148	229	289	348	513	886	1284	2090
12	9.23	16.37	25.7	42.1	65.8	108	154	239	302	364	535	925	1341	2183
13	9.60	17.04	26.8	43.8	68.4	112	160	249	314	379	557	963	1396	2272
14	9.97	17.68	27.8	45.5	71.0	116	166	258	326	393	578	999	1448	2358
15	10.31	18.31	28.8	47.1	73.5	121	172	267	337	407	599	1034	1499	2441
16	10.65	18.91	29.7	48.6	75.9	125	178	276	348	420	618	1068	1548	2521
18	11.30	20.05	31.5	51.6	80.5	132	189	293	370	446	656	1133	1642	2674
20	11.91	21.14	33.2	54.4	84.9	139	199	309	390	470	691	1194	1731	2818
22	12.49	22.17	34.8	57.0	89.0	146	209	324	409	493	725	1253		
24	13.05	23.15	36.4	59.5	93.0	153	218	338	427	515	757	1308		
26	13.58	24.10	37.9	62.0	96.8	159	227	352	444	536	788	1362		
28	14.09	25.01	39.3	64.3	100.4	165	235	365	461	556	818	1413		
30	14.59	25.89	40.7	66.6	104.0	171	244	378	477	575	846	1463		
32	15.07	26.74	42.0	68.8	107.4	176	252	391	493	594	874	1511		
34	15.53	27.56	43.3	70.9	110.7	182	259	403	508	612	901	1557		
36	15.98	28.36	44.6	72.9	113.9	187	267	414	523	630	927	1602		
38	16.42	29.14	45.8	74.9	117.0	192	274	426	537	647	953	1646		
40	16.84	29.89	47.0	76.9	120.0	197	281	437	551	664	977	1689		
42	17.26	30.63	48.1	78.8	123.0	202	288	448	564	681	1002			
44	17.67	31.35	49.3	80.6	125.9	207	295	458	578	697	1025			
46	18.06	32.06	50.4	82.4	128.7	211	302	468	591	712	1048			
48	18.45	32.75	51.5	84.2	131.5	216	308	478	603	728	1071			
50	18.83	33.42	52.5	85.9	134.2	220	315	488	616	743	1093			
52	19.21	34.08	53.6	87.6	136.9	225	321	498	628	757	1114			
54	19.57	34.73	54.6	89.3	139.5	229	327	507	640	772	1136			
56	19.93	35.37	55.6	90.9	142.0	233	333	517	652	786	1157			
58	20.28	36.00	56.6	92.6	144.6	237	339	526	663	800	1177			
60	20.63	36.61	57.5	94.1	147.0	241	345	535	675	814	1197			
65	21.47	38.11	59.9	98.0	153.0	251	359	557	702	847	1246			
70	22.28	39.54	62.1	101.7	158.8	260	372	578	729	879	1293			
75	23.06	40.93	64.3	105.3	164.4	270	385	598	754					
80	23.82	42.27	66.4	108.7	169.8	278	398	618						
85	24.55	43.58	68.5	112.1	175.0	287	410	637						
90	25.27	44.84	70.5	115.3	180.1	295	422	655						
95	25.96	46.07	72.4	118.5	185.0	303	434	673						
100	26.63	47.26	74.3	121.5	189.8	311	445	691						
110	27.93	49.57	77.9	127.5	199.1	327	467							
120	29.17	51.77	81.4	133.1	207.9	341	487							
130	30.37	53.89	84.7	138.6	216.4	355	507							
140	31.51	55.92	87.9	143.8	224.6	368	526							
150	32.62	57.89	91.0	148.9	232.5	381	545							
160	33.69	59.78	93.9	153.7	240.1	394								
170	34.72	61.62	96.8	158.5	247.5	406								
180	35.73	63.41	99.6	163.1	254.7	418								
190	36.71	65.15	102.4	167.5	261.6	429								
200	37.66	66.84	105.0	171.9										
220	39.50	70.10	110.2	180.3										
240	41.26	73.22	115.1	188.3										
260	42.94	76.21	119.8	196.0										
280	44.57	79.09	124.3											
300	46.13	81.86	128.6											
320	47.64	84.55	132.9											
340	49.11	87.15	137.0											
360	50.53	89.68	140.9											
380	51.92	92.13												
400	53.27	94.53												
420	54.58	96.86												

Starflow P Series Capacity Tables

Air Calculation according to API STD 520 Capacities at 10% overpressure scfm at 32°F

Orifices sq.in	Set pressure - Psig													
	D 0.110	E 0.196	F 0.307	G 0.503	H 0.785	J 1.287	K 1.838	L 2.853	M 3.60	N 4.34	P 6.38	Q 11.05	R 16	T 26
10	52	92	145	237	370	606	866	1344	1696	2045	3006	5207	7540	12252
15	63	112	176	288	449	736	1051	1632	2059	2483	3650	6322	9153	14874
20	74	132	207	338	528	866	1237	1920	2423	2921	4293	7436	10767	17496
25	85	152	238	389	607	996	1422	2208	2786	3358	4937	8550	12380	20118
30	96	171	269	440	687	1126	1608	2495	3149	3796	5580	9665	13994	22740
35	107	191	299	491	766	1255	1793	2783	3512	4234	6224	10779	15608	25362
40	118	211	330	541	845	1385	1978	3071	3875	4671	6867	11893	17221	27984
45	129	231	361	592	924	1515	2164	3358	4238	5109	7510	13008	18835	30606
50	141	250	392	643	1003	1645	2349	3646	4601	5547	8154	14122	20448	33228
55	152	270	423	694	1082	1775	2534	3934	4964	5984	8797	15236	22062	35851
60	163	290	454	744	1162	1904	2720	4222	5327	6422	9441	16351	23675	38473
65	174	310	485	795	1241	2034	2905	4509	5690	6860	10084	17465	25289	41095
70	185	330	516	846	1320	2164	3090	4797	6053	7297	10727	18580	26903	43717
75	196	349	547	896	1399	2294	3276	5085	6416	7735	11371	19694	28516	46339
80	207	369	578	947	1478	2424	3461	5373	6779	8173	12014	20808	30130	48961
85	218	389	609	998	1557	2553	3647	5660	7142	8610	12658	21923	31743	51583
90	229	409	640	1049	1637	2683	3832	5948	7505	9048	13301	23037	33357	54205
95	240	428	671	1099	1716	2813	4017	6236	7868	9486	13944	24151	34970	56827
100	252	448	702	1150	1795	2943	4203	6523	8231	9923	14588	25266	36584	59449
110	274	488	764	1252	1953	3202	4573	7099	8958	10799	15875	27495	39811	64693
120	296	527	826	1353	2112	3462	4944	7674	9684	11674	17162	29723	43038	69937
130	318	567	888	1454	2270	3721	5315	8250	10410	12549	18448	31952	46265	75181
140	340	606	950	1556	2428	3981	5685	8825	11136	13425	19735	34181	49493	80425
150	362	646	1012	1657	2587	4241	6056	9401	11862	14300	21022	36410	52720	85669
160	385	685	1073	1759	2745	4500	6427	9976	12588	15176	22309	38638	55947	90914
180	429	764	1197	1962	3062	5019	7168	11127	14040	16926	24882	43096	62401	101402
200	473	843	1321	2165	3378	5539	7910	12278	15492	18677	27456	47553	68855	111890
220	518	923	1445	2368	3695	6058	8651	13429	16945	20428	30030	52011	75310	122378
240	562	1002	1569	2570	4012	6577	9393	14580	18397	22178	32603	56468	81764	132866
260	606	1081	1693	2773	4328	7096	10134	15730	19849	23929	35177	60926	88218	143355
280	651	1160	1817	2976	4645	7615	10875	16881	21301	25680	37751	65383	94672	153843
300	695	1239	1940	3179	4962	8134	11617	18032	22754	27431	40324	69841	101127	164331
320	740	1318	2064	3382	5278	8654	12358	19183	24206	29181	42898	74298		
340	784	1397	2188	3585	5595	9173	13100	20334	25658	30932	45472	78756		
360	828	1476	2312	3788	5912	9692	13841	21485	27110	32683	48045	83213		
380	873	1555	2436	3991	6228	10211	14583	22636	28562	34434	50619	87671		
400	917	1634	2560	4194	6545	10730	15324	23787	30015	36184	53192	92128		
420	961	1713	2683	4397	6862	11249	16066	24937	31467	37935	55766	96586		
440	1006	1792	2807	4600	7178	11769	16807	26088	32919	39686	58340	101043		
460	1050	1871	2931	4802	7495	12288	17548	27239	34371	41436	60913	105500		
480	1095	1950	3055	5005	7811	12807	18290	28390	35823	43187	63487	109958		
500	1139	2029	3179	5208	8128	13326	19031	29541	37276	44938	66061	114415		
520	1183	2109	3303	5411	8445	13845	19773	30692	38728	46689	68634	118873		
540	1228	2188	3426	5614	8761	14364	20514	31843	40180	48439	71208	123330		
560	1272	2267	3550	5817	9078	14884	21256	32994	41632	50190	73782	127788		
580	1316	2346	3674	6020	9395	15403	21997	34144	43084	51941	76355	132245		
600	1361	2425	3798	6223	9711	15922	22738	35295	44537	53691	78929	136703		
650	1472	2622	4108	6730	10503	17220	24592	38173	48167	58068	85363			
700	1583	2820	4417	7237	11295	18518	26446	41050	51798	62445	91797			
750	1694	3018	4727	7745	12086	19816	28299	43927	55428	66822	98231			
800	1805	3215	5036	8252	12878	21114	30153	46804	59059	71199	104665			
850	1916	3413	5346	8759	13670	22411	32006	49681	62689	75575	111099			
900	2026	3611	5656	9266	14461	23709	33860	52558	66320	79952	117534			
950	2137	3808	5965	9774	15253	25007	35714	55436	69950	84329	123968			
1000	2248	4006	6275	10281	16045	26305	37567	58313	73581	88706	130402			
1100	2470	4401	6894	11295	17628	28901	41274	64067	80842					
1200	2692	4797	7513	12310	19211	31497	44981	69822						
1300	2914	5192	8132	13324	20795	34093	48689	75576						
1400	3136	5587	8752	14339	22378	36688	52396	81330						
1500	3358	5983	9371	15354	23961	39284	56103	87085						
1600	3579	6378	9990	16368	25545	41880	59810							
1700	3801	6773	10609	17383	27128	44476	63517							
1800	4023	7169	11228	18397	28711	47072	67225							
1900	4245	7564	11848	19412	30295	49668	70932							
2000	4467	7959	12467	20426	31878	52263	74639							
2200	4911	8750	13705	22455	35044	57455	82053							
2400	5354	9541	14944	24484	38211	62647								
2600	5798	10331	16182	26513	41378	67838								
2800	6242	11122	17421	28542										
3000	6686	11913	18659	30572										
3200	7129	12703	19897	32601										
3400	7573	13494	21136	34630										
3600	8017	14284	22374	36659										
3800	8461	15075	23613											
4000	8904	15866	24851											
4500	10014	17842	27947											
5000	11123	19819	31043											

Starflow P Series Capacity Tables

Saturated steam Calculation according to API STD 520 Capacities at 10% overpressure lbs/hr

Orifices sq.in. Set pressure - Psig	D	E	F	G	H	J	K	L	M	N	P	Q	R	T
	0.110	0.196	0.307	0.503	0.785	1.287	1.838	2.853	3.60	4.34	6.38	11.05	16	26
10	142	252	395	648	1011	1657	2367	3674	4636	5589	8216	14230	20605	33483
15	172	306	480	786	1227	2012	2874	4460	5628	6785	9975	17276	25014	40648
20	202	360	565	925	1444	2367	3380	5247	6620	7981	11733	20321	29424	47814
25	233	414	649	1064	1660	2721	3887	6033	7613	9177	13491	23366	33834	54980
30	263	468	734	1202	1876	3076	4393	6819	8605	10373	15249	26412	38243	62145
35	293	522	818	1341	2093	3431	4900	7606	9597	11570	17008	29457	42653	69311
40	324	577	903	1480	2309	3786	5406	8392	10589	12766	18766	32502	47062	76476
45	354	631	988	1618	2525	4140	5913	9178	11581	13962	20524	35548	51472	83642
50	384	685	1072	1757	2742	4495	6419	9964	12573	15158	22283	38593	55882	90808
55	415	739	1157	1895	2958	4850	6926	10751	13566	16354	24041	41639	60291	97973
60	445	793	1241	2034	3174	5204	7433	11537	14558	17550	25799	44684	64701	105139
65	475	847	1326	2173	3391	5559	7939	12323	15550	18746	27558	47729	69110	112304
70	505	901	1411	2311	3607	5914	8446	13110	16542	19942	29316	50775	73520	119470
75	536	955	1495	2450	3823	6268	8952	13896	17534	21138	31074	53820	77930	126636
80	566	1009	1580	2589	4040	6623	9459	14682	18526	22335	32833	56866	82339	133801
85	596	1063	1664	2727	4256	6978	9965	15468	19518	23531	34591	59911	86749	140967
90	627	1117	1749	2866	4472	7333	10472	16255	20511	24727	36349	62956	91158	148132
95	657	1171	1834	3004	4689	7687	10978	17041	21503	25923	38108	66002	95568	155298
100	687	1225	1918	3143	4905	8042	11485	17827	22495	27119	39866	69047	99978	162464
110	748	1333	2088	3420	5338	8751	12498	19400	24479	29511	43383	75138	108797	176795
120	809	1441	2257	3698	5771	9461	13511	20972	26464	31903	46899	81229	117616	191126
130	869	1549	2426	3975	6203	10170	14524	22545	28448	34296	50416	87319	126435	205457
140	930	1657	2595	4252	6636	10880	15537	24118	30432	36688	53933	93410	135254	219788
150	991	1765	2764	4529	7069	11589	16550	25690	32417	39080	57449	99501	144074	234120
160	1051	1873	2934	4807	7501	12298	17564	27263	34401	41472	60966	105592	152893	248451
180	1172	2089	3272	5361	8367	13717	19590	30408	38370	46257	67999	117773	170531	277113
200	1294	2305	3611	5916	9232	15136	21616	33553	42338	51041	75033	129955	188170	305775
220	1415	2521	3949	6470	10097	16555	23642	36698	46307	55825	82066	142136	205808	334438
240	1536	2737	4287	7025	10963	17973	25668	39843	50275	60610	89099	154318	223446	363100
260	1657	2953	4626	7579	11828	19392	27695	42988	54244	65394	96133	166499	241085	391763
280	1779	3169	4964	8134	12694	20811	29721	46134	58213	70179	103166	178681	258723	420425
300	1900	3385	5303	8688	13559	22230	31747	49279	62181	74963	110199	190862	276361	449087
320	2021	3601	5641	9243	14424	23649	33773	52424	66150	79747	117232	203044		
340	2143	3818	5980	9797	15290	25067	35799	55569	70119	84532	124266	215225		
360	2264	4034	6318	10352	16155	26486	37826	58714	74087	89316	131299	227407		
380	2385	4250	6656	10906	17021	27905	39852	61859	78056	94101	138332	239588		
400	2506	4466	6995	11461	17886	29324	41878	65004	82025	98885	145366	251770		
420	2628	4682	7333	12015	18751	30743	43904	68150	85993	103670	152399	263951		
440	2749	4898	7672	12570	19617	32161	45930	71295	89962	108454	159432	276133		
460	2870	5114	8010	13124	20482	33580	47957	74440	93930	113238	166466	288314		
480	2991	5330	8349	13679	21347	34999	49983	77585	97899	118023	173499	300496		
500	3113	5546	8687	14233	22213	36418	52009	80730	101868	122807	180532	312677		
520	3234	5762	9025	14788	23078	37836	54035	83875	105836	127592	187565	324859		
540	3355	5978	9364	15342	23944	39255	56062	87020	109805	132376	194599	337040		
560	3476	6194	9702	15897	24809	40674	58088	90166	113774	137160	201632	349222		
580	3598	6410	10041	16451	25674	42093	60114	93311	117742	141945	208665	361403		
600	3719	6626	10379	17006	26540	43512	62140	96456	121711	146729	215699	373585		
650	4022	7167	11225	18392	28703	47059	67206	104319	131632	158690	233282			
700	4325	7707	12071	19778	30867	50606	72271	112182	141554	170651	250865			
750	4628	8247	12918	21165	33030	54153	77337	120044	151476	182612	268449			
800	4932	8787	13764	22551	35194	57700	82402	127907	161397	194573	286032			
850	5235	9327	14610	23937	37357	61246	87468	135770	171319	206534	303615			
900	5538	9868	15456	25323	39520	64793	92533	143633	181240	218495	321198			
950	5841	10408	16302	26710	41684	68340	97599	151496	191162	230456	338782			
1000	6144	10948	17148	28096	43847	71887	102664	159359	201084	242417	356365			
1100	6751	12028	18840	30868	48174	78981	112795	175084	220927					
1200	7357	13109	20532	33641	52501	86075	122926	190810						
1300	7963	14189	22225	36413	56828	93169	133057	206536						
1400	8569	15269	23917	39186	61155	100263	143189	222262						
1500	9176	16350	25609	41959	65482	107357	153320	237987						
1600	9782	17430	27301	44731	69809	114451	163451							
1700	10388	18510	28993	47504	74136	121545	173582							
1800	10995	19591	30685	50276	78463	128639	183713							
1900	11601	20671	32378	53049	82790	135733	193844							
2000	12207	21751	34070	55821	87117	142827	203975							
2200	13420	23912	37454	61366	95770	157015	224237							
2400	14633	26073	40839	66911	104424	171203								
2600	15845	28234	44223	72456	113078	185390								
2800	17058	30394	47607	78001										

Starflow P Series Capacity Tables

Water **Calculation according to API STD 520** **Capacities at 10% overpressure usgpm**

Orifices sq.in Set pressure - Psig	D	E	F	G	H	J	K	L	M	N	P	Q	R	T
	0.110	0.196	0.307	0.503	0.785	1.287	1.838	2.853	3.60	4.34	6.38	11.05	16	26
10	142	252	395	648	1011	1657	2367	3674	4636	5589	8216	14230	20605	33483
15	172	306	480	786	1227	2012	2874	4460	5628	6785	9975	17276	25014	40648
20	202	360	565	925	1444	2367	3380	5247	6620	7981	11733	20321	29424	47814
25	233	414	649	1064	1660	2721	3887	6033	7613	9177	13491	23366	33834	54980
30	263	468	734	1202	1876	3076	4393	6819	8605	10373	15249	26412	38243	62145
35	293	522	818	1341	2093	3431	4900	7606	9597	11570	17008	29457	42653	69311
40	324	577	903	1480	2309	3786	5406	8392	10589	12766	18766	32502	47062	76476
45	354	631	988	1618	2525	4140	5913	9178	11581	13962	20524	35548	51472	83642
50	384	685	1072	1757	2742	4495	6419	9964	12573	15158	22283	38593	55882	90808
55	415	739	1157	1895	2958	4850	6926	10751	13566	16354	24041	41639	60291	97973
60	445	793	1241	2034	3174	5204	7433	11537	14558	17550	25799	44684	64701	105139
65	475	847	1326	2173	3391	5559	7939	12323	15550	18746	27558	47729	69110	112304
70	505	901	1411	2311	3607	5914	8446	13110	16542	19942	29316	50775	73520	119470
75	536	955	1495	2450	3823	6268	8952	13896	17534	21138	31074	53820	77930	126636
80	566	1009	1580	2589	4040	6623	9459	14682	18526	22335	32833	56866	82339	133801
85	596	1063	1664	2727	4256	6978	9965	15468	19518	23531	34591	59911	86749	140967
90	627	1117	1749	2866	4472	7333	10472	16255	20511	24727	36349	62956	91158	148132
95	657	1171	1834	3004	4689	7687	10978	17041	21503	25923	38108	66002	95568	155298
100	687	1225	1918	3143	4905	8042	11485	17827	22495	27119	39866	69047	99978	162464
110	748	1333	2088	3420	5338	8751	12498	19400	24479	29511	43383	75138	108797	176795
120	809	1441	2257	3698	5771	9461	13511	20972	26464	31903	46899	81229	117616	191126
130	869	1549	2426	3975	6203	10170	14524	22545	28448	34296	50416	87319	126435	205457
140	930	1657	2595	4252	6636	10880	15537	24118	30432	36688	53933	93410	135254	219788
150	991	1765	2764	4529	7069	11589	16550	25690	32417	39080	57449	99501	144074	234120
160	1051	1873	2934	4807	7501	12298	17564	27263	34401	41472	60966	105592	152893	248451
180	1172	2089	3272	5361	8367	13717	19590	30408	38370	46257	67999	117773	170531	277113
200	1294	2305	3611	5916	9232	15136	21616	33553	42338	51041	75033	129955	188170	305775
220	1415	2521	3949	6470	10097	16555	23642	36698	46307	55825	82066	142136	205808	334438
240	1536	2737	4287	7025	10963	17973	25668	39843	50275	60610	89099	154318	223446	363100
260	1657	2953	4626	7579	11828	19392	27695	42988	54244	65394	96133	166499	241085	391763
280	1779	3169	4964	8134	12694	20811	29721	46134	58213	70179	103166	178681	258723	420425
300	1900	3385	5303	8688	13559	22230	31747	49279	62181	74963	110199	190862	276361	449087
320	2021	3601	5641	9243	14424	23649	33773	52424	66150	79747	117232	203044		
340	2143	3818	5980	9797	15290	25067	35799	55569	70119	84532	124266	215225		
360	2264	4034	6318	10352	16155	26486	37826	58714	74087	89316	131299	227407		
380	2385	4250	6656	10906	17021	27905	39852	61859	78056	94101	138332	239588		
400	2506	4466	6995	11461	17886	29324	41878	65004	82025	98885	145366	251770		
420	2628	4682	7333	12015	18751	30743	43904	68150	85993	103670	152399	263951		
440	2749	4898	7672	12570	19617	32161	45930	71295	89962	108454	159432	276133		
460	2870	5114	8010	13124	20482	33580	47957	74440	93930	113238	166466	288314		
480	2991	5330	8349	13679	21347	34999	49983	77585	97899	118023	173499	300496		
500	3113	5546	8687	14233	22213	36418	52009	80730	101868	122807	180532	312677		
520	3234	5762	9025	14788	23078	37836	54035	83875	105836	127592	187565	324859		
540	3355	5978	9364	15342	23944	39255	56062	87020	109805	132376	194599	337040		
560	3476	6194	9702	15897	24809	40674	58088	90166	113774	137160	201632	349222		
580	3598	6410	10041	16451	25674	42093	60114	93311	117742	141945	208665	361403		
600	3719	6626	10379	17006	26540	43512	62140	96456	121711	146729	215699	373585		
650	4022	7167	11225	18392	28703	47059	67206	104319	131632	158690	233282			
700	4325	7707	12071	19778	30867	50606	72271	112182	141554	170651	250865			
750	4628	8247	12918	21165	33030	54153	77337	120044	151476	182612	268449			
800	4932	8787	13764	22551	35194	57700	82402	127907	161397	194573	286032			
850	5235	9327	14610	23937	37357	61246	87468	135770	171319	206534	303615			
900	5538	9868	15456	25323	39520	64793	92533	143633	181240	218495	321198			
950	5841	10408	16302	26710	41684	68340	97599	151496	191162	230456	338782			
1000	6144	10948	17148	28096	43847	71887	102664	159359	201084	242417	356365			
1100	6751	12028	18840	30868	48174	78981	112795	175084	220927					
1200	7357	13109	20532	33641	52501	86075	122926	190810						
1300	7963	14189	22225	36413	56828	93169	133057	206536						
1400	8569	15269	23917	39186	61155	100263	143189	222262						
1500	9176	16350	25609	41959	65482	107357	153320	237987						
1600	9782	17430	27301	44731	69809	114451	163451							
1700	10388	18510	28993	47504	74136	121545	173582							
1800	10995	19591	30685	50276	78463	128639	183713							
1900	11601	20671	32378	53049	82790	135733	193844							
2000	12207	21751	34070	55821	87117	142827	203975							
2200	13420	23912	37454	61366	95770	157015	224237							
2400	14633	26073	40839	66911	104424	171203								
2600	15845	28234	44223	72456	113078	185390								
2800	17058	30394	47607	78001										
3000	18271	32555	50992	83547										
3200	19483	34716	54376	89092										
3400	20696	36876	57760	94637										
3600	21909	39037	61145	100182										
3800	23121	41198	64529											
4000	24334	43358	67913											
4500	27365	48760	76374											
5000	30397	54162	84835											

Starflow Model Coding

Select the correct model number and designate the applicable options or accessories when ordering STARFLOW valves.

Model code system

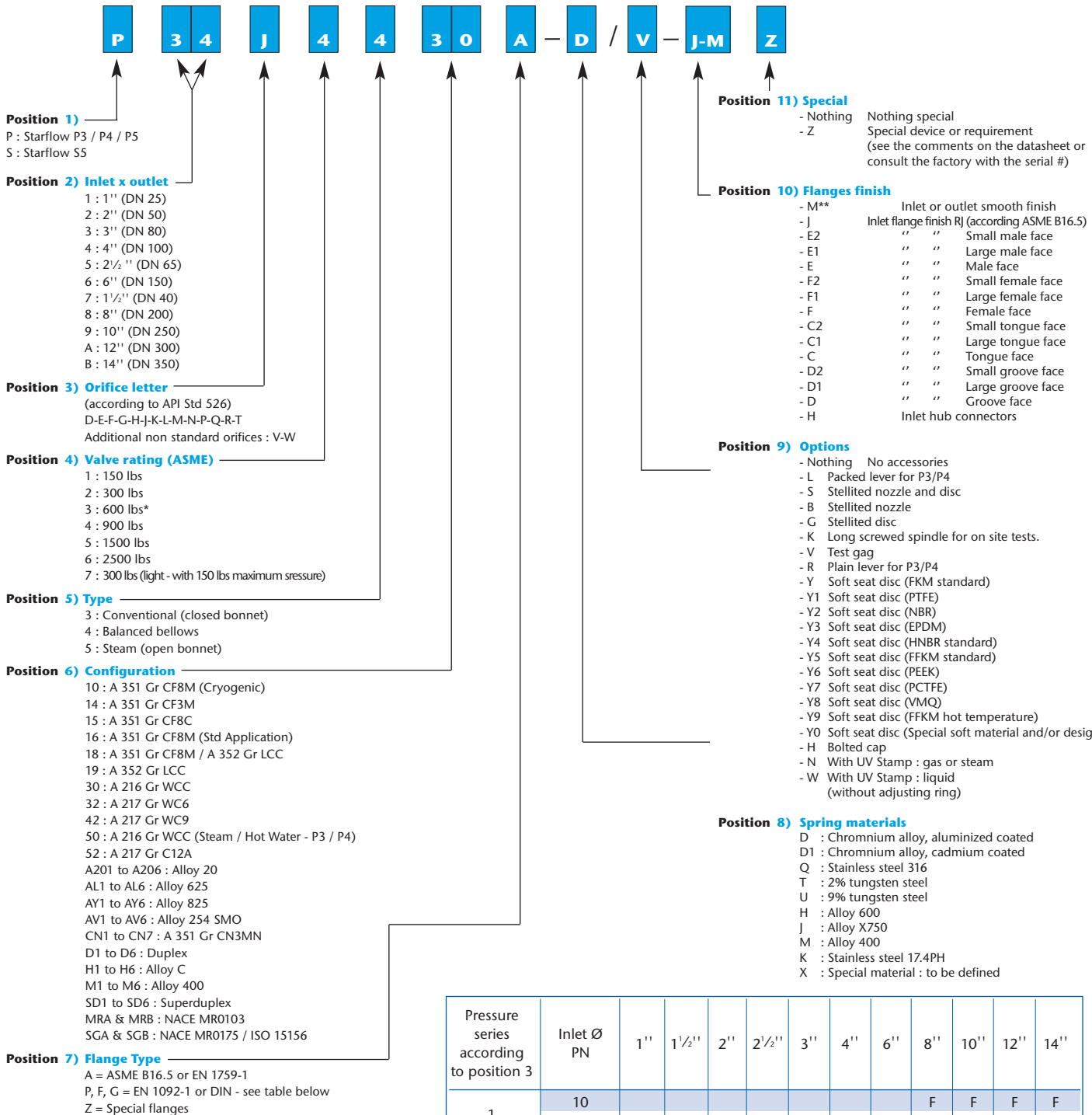

* Except T orifice is Class 300 flange.
** Today standard

Pressure series according to position 3	Inlet Ø PN	1"	1½"	2"	2½"	3"	4"	6"	8"	10"	12"	14"
1	10								F	F	F	F
	16				P	P	P	P	G	G	G	G
2	25	P	P	P					F	F	F	F
	40				P	P	P	P	G	G	G	G
3	64			F	F	F	F	F	-	-	-	-
	100	P	P	G	G	G	G	G	-	-	-	-

How to choose a STARFLOW valve

1 - Data

- Required flow rate
- Set pressure
- Allowable overpressure
- Fluid data
 - gas (molecular weight, C_p/C_v , compressibility factor)
 - liquid (density, viscosity)
 - steam (temperature)
- Service conditions (back pressure, temperature)
- Environmental requirements (corrosion)
- Flange standards

2 - Orifice selection

Using capacity tables for known fluids (air/steam/water) and given overpressure, select the orifice size corresponding to minimum required flow rate.

3 - Valve selection

Using the capacity table or relevant orifice selection chart, select the model number that is suitable for pressure/temperature rating.

4 - Valve characteristics

- Selection table shows inlet x outlet sizes and flange ratings as well as valve dimensions and weights.
- Bills of material may be obtained from the appropriate section of this catalogue.

5 - Options and accessories

Options and accessories must be separately specified.

Order information

For proper and timely processing of your order, the following information should be given :

- 1 - Quantity
- 2 - Inlet and outlet size
- 3 - STARFLOW model number
- 4 - Inlet and outlet flange rating and facing if different from standard
- 5 - Materials of construction if different from standard
- 6 - Soft seat material required
- 7 - Set pressure
- 8 - Maximum inlet pressure
- 9 - Maximum allowable overpressure
- 10 - Service : liquid : specific gravity (water= 1), viscosity - gas : molecular weight and compressibility factor - steam : temperature
- 11 - Back pressure, constant or variable, and value
- 12 - Required capacity
- 13 - Accessories : lever, test gag, other
- 14 - Code requirements

When possible, we check the sizing and selection of the valves.

Spring Loaded Safety Relief Valves

Body in carbon steel, stainless steel, alloy and exotic materials; with bellows, lever and other accessories, to ensure suitability for all service conditions.



Starflow SS (steam only)
ASME Section VIII Div. 1
(UV Stamp)
API Std 526
Full Nozzle - Enlarged guide
Inlet size : 1" to 12"
Rating : 150# to 2500#
Temp : up to 540°C



Starflow P3 / P4 / P5
ASME Section VIII Div. 1
(UV Stamp)
API Std 526
Full Nozzle
Inlet size : 1" to 12"
Rating : 150# to 2500#
Temp : -196°C up to +540°C

Pilot Operated Pressure Relief Valves

The Sarasin-RSBD pilot-operated pressure relief valve is an autonomous valve. It does not need any auxiliary source of power to operate. The advanced technology of Sarasin-RSBD valves has been adopted by the nuclear industry, French and U.S. Navies and by the Oil and Gas industries. It is complementary to the range of spring-loaded safety relief valves and covers a wide field of applications including severe conditions.



76 Series
Full nozzle



78 Series
Semi nozzle



86 Series
Full nozzle

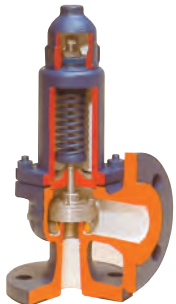

63 Series
ISO 4126
Semi-nozzle
Inlet size : 3/4" to 10"
Rating : 150# to 300#
Temp : -196°C up to +330°C



9 Series
ASME Section VIII Div. 1
Portable SRV - Full nozzle
Screwed / Flanged / Welded
Size : 1/2" to 1 1/2"
Rating : 150# to 2500#
Temp : -196°C up to +400°C

Advantages of the Sarasin-RSBD Pilot-operated pressure relief valve

- leak-free pilot
- on-off opening, fully open or closed (limited maintenance)
- perfect tightness (no production loss)
- perfect operation, even with capacities smaller than those rated for all types of fluids
- excellent repeatability and reliability
- adjustable blowdown (pop action)
- no pressure/flow limit
- with additional equipment (solenoid valve), the safety relief valve can be used as a discharge valve.

To meet the most varied requirements, Sarasin-RSBD selects the appropriate pilot detector for the safety relief valve required (semi or full nozzle, with bellows, piston etc.)



Starvalve Changeover Valves
Low pressure drop COV
Standard COV
Combined valve with linkage system
Sizes : 1/2" - 10"
Pressure : up to 100 barg
Temp : -196°C up to +427°C
Mat : CS - SS



Gas - Liquid
Modulating action



Gas
Pop action



High temperature steam - Gas
Pop action

Weir Power & Industrial France

Rue J.B. Grison - ZI Bois Rigault
62880 Vendin Le Vieil - France
Tel: +33 (0) 3 21 79 54 50
Fax: +33 (0) 3 21 28 62 00
Email: sarasin.rsbd@weirgroup.com

Weir-BDK Valves

Unit WEIR India Pvt Limited
47 / 48, Gokul Road,
Hubli-580030 - Karnataka - India
Tel: +91 836 4248222 / 4248223
Fax: +91 836 2330799
Email: india.sarasin-rsbd@weirgroup.com

Excellent
Engineering
Solutions

