

TOP ENTRY PREMIUM VALVE

EXTREME SAFE AND RELIABLE

LNG/LPG SYSTEMS
LOW TEMPERATURES
OXYGEN
CHEMICAL PROCESSES
SHIPBUILDING
AEROSPACE
HYDROGEN



QUADAX® TOP ENTRY

FOR A RELIABLE PROCESS

RELIABLY TIGHT

A cryogenic test according to BS 6364 carried out by an external testing institute in connection with an endurance test according to EN 12567 confirm a tightness which are far above the requirements of the standard. After 500 switches there could not be measured any leakage any more.

- Distribution, customer service & production
- Distribution & customer service
- Distribution

TRIMMED FOR PERFORMANCE

The 4-offset premium valve provides a completely round seat and sealing geometry. Advantages:

- All around identical material thickness
- Uniform expansion in case of temperature fluctuations
- Bubble-tight also at -196 °C
- Frictionless
- Long service life



LOW FUGITIVE EMISSIONS

Thanks to the special shaft and top flange seal, only low to hardly measurable fugitive emissions can be detected and thus clearly lie below the requirements of the standards.



REDUCED MAINTENANCE COSTS

QUADAX® PREMIUM VALVES are low-maintenance items. Control and maintenance work can take place with a minimum of effort while the valve remains in the pipeline.



CREATED FOR EXTREME

Temperatures

-270 °C up to +800 °C

PN 10 – 160 / ANSI cl. 150 – 900, experience with high-quality alloys



SAFETY FOR YOUR PERSONNEL

Efficient replacement of all parts including shaft bearings in a safe environment with free access for the service personnel is possible regardless of the valve size.

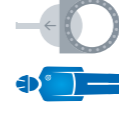

CERTIFIED

BAM certification

EAC certification

Fire safe according to ISO 10497, API 607, BS 6755

Tightness leakage rate A EN12266 / API 598

SIL 3

ATEX certification

DNV type approval

QUADAX® complies with the legal requirements EN 1473-2016 for "Installations and Equipment for Liquefied Natural Gas - Design of Onshore Installations". Confirmed by various order-specific test reports.



SATISFIED CUSTOMERS

The large number of satisfied customers worldwide confirm the top quality and the functional advantages of the QUADAX® butterfly and control valves.



LIGHTER AND MORE COMPACT

than a ball valve leading to lower weight and thus facilitating installation in pipelines. Lower torques enable more compact actuators.



MADE IN GERMANY

QUADAX® PRECISION

In our production, quality, expertise and experience all come together – Made in Germany.

Our innovative premium valves are produced on modern, fully equipped 5-axis machining centres. Our manufacturing facilities cover an area of 10,000 m² production, assembly and storage. Furthermore, we also have comprehensive state-of-the-art testing facilities. Every single work step, from the technical drawing to the final inspection before delivery to the customer, is subject to a clearly defined procedure. This ensures that we can always achieve our own high quality standards.

Only the best equipment can provide the basis for products that set standards!

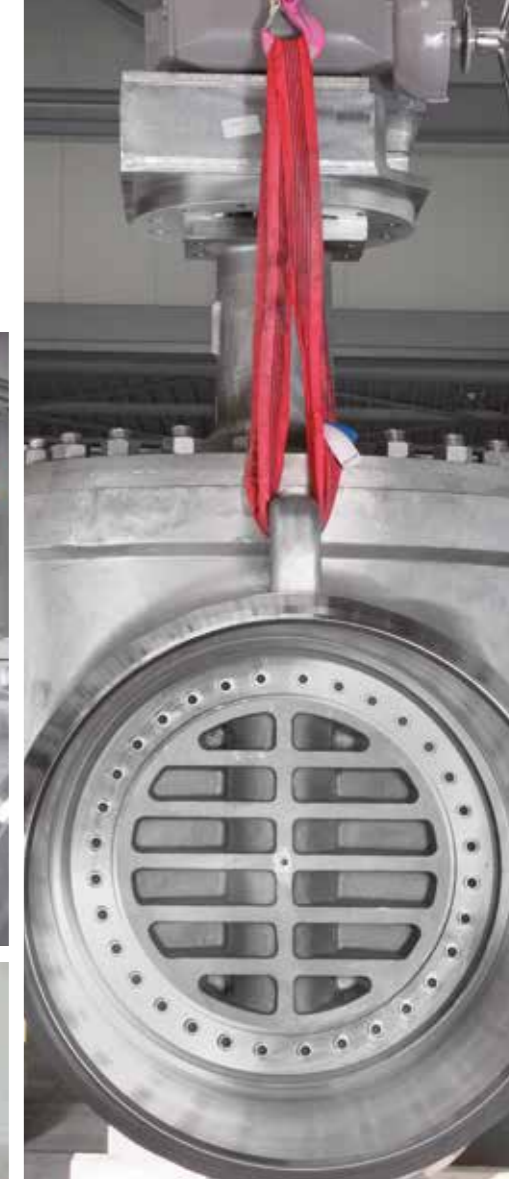

Technical
data - PDF
TOP ENTRY



MADE FOR THE EXTREME

QUALITY AND SAFETY

KEY DATA

Premium valve:
4-offset

Pressure range:
PN 10 - 160
ANSI cl. 150 - 900

Nominal width:
DN 100-1000 mm

Connection:
Welding ends

When it comes to controlling, regulating and monitoring a wide variety of media, also under extreme conditions, it is important to have a reliable partner. Innovation and expertise make us to be the reliable partner. State-of-the-art production technologies make it possible for us to implement the innovative design principle of the 4-offset premium valve. Extreme temperatures from -270 °C to +800 °C and pressure ranges up to 160 bar are no challenge for QUADAX®.

Many critical media such as hydrogen are colourless, odourless and tasteless. Furthermore, hydrogen in connection with oxygen reacts flammable to explosive. With such critical and safety-relevant applications, 100% tight and safe valves are needed. QUADAX® has repeatedly proven this 100% tightness with international large-scale projects and special endurance tests with external testing institutes. Our 4-offset premium valves verifiably offer the lowest fugitive emission values in the market.

Our Top Entry premium valves additionally comply with all the requirements of EN 1473-2016 for valves and provide full tightness also with clean, liquid and gaseous cryogenic applications with extreme temperature differences.

-270 °C up to
+800 °C

-450 °F up to
+1472 °F



1. High-precision work
2. Final quality inspection
3. High availability for short delivery times



THE COMPARISON

4-OFFSET VS. 3-OFFSET PRINCIPLE

4-OFFSET PREMIUM VALVE

The 4-offset premium valve has an elliptical output cone. The cut at a specific angle results in a rounder and thus larger sealing seat.

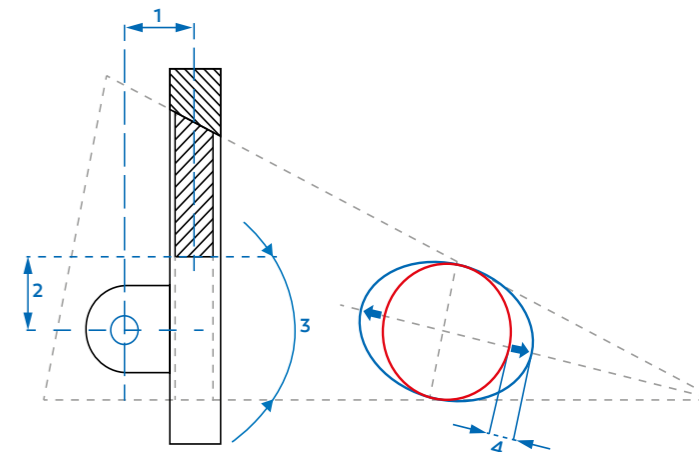

4-offset QUADAX® PREMIUM VALVES

The 4-offset premium valve provides a completely round seat and sealing geometry.

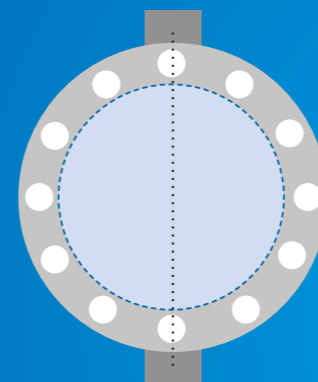

VS.

Conventional 3-offset eccentric butterfly valves

A conventional 3-offset eccentric butterfly valve functions with an elliptical seat and sealing geometry.

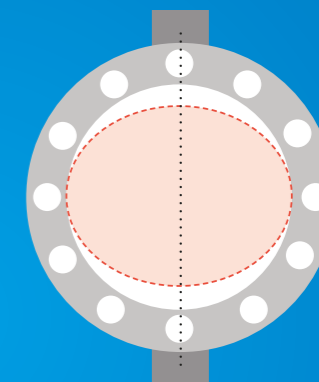

- Frictionless
- Higher KV/CV values
- Highest tightness / no leaks (even in the most extreme conditions)
- Lower torques



- Wear due to friction
- Danger of leakages
- More maintenance prone

THE EFFICIENT AND SAFE SOLUTION!

TOP ENTRY

Although the premium valves are basically low-maintenance for clean, liquid and gaseous cryogenic applications, maintenance intervals or extraordinary repairs might be required. With the QUADAX® TOP ENTRY, the central upper flange can be removed and the internal components can be easily pulled out of the valve body.

Efficient replacement of all parts including shaft bearings in a safe environment with free access for the service personnel is possible regardless of the valve size.

INDUSTRIES

- ▮ LNG/LPG SYSTEMS
- ▮ LOW TEMPERATURES
- ▮ OXYGEN
- ▮ CHEMICAL PROCESSES
- ▮ SHIPBUILDING
- ▮ AEROSPACE
- ▮ HYDROGEN



QUADAX® PREMIUM VALVE TOP ENTRY

Especially developed for LNG applications

Maintenance and repair work can take place with a minimum of effort while the valve remains in the pipeline.

100% tight - no leaks

CUSTOMERS



THE COMPARISON

QUADAX® TOP ENTRY VS. SIDE ENTRY

The QUADAX® TOP ENTRY has been especially developed for LNG applications and ensures that control and maintenance work can be carried out safely and easily without further risks occurring for the service personnel.

Our QUADAX® TOP ENTRY with 4-offset premium valves:

Side Entry from a competitor:

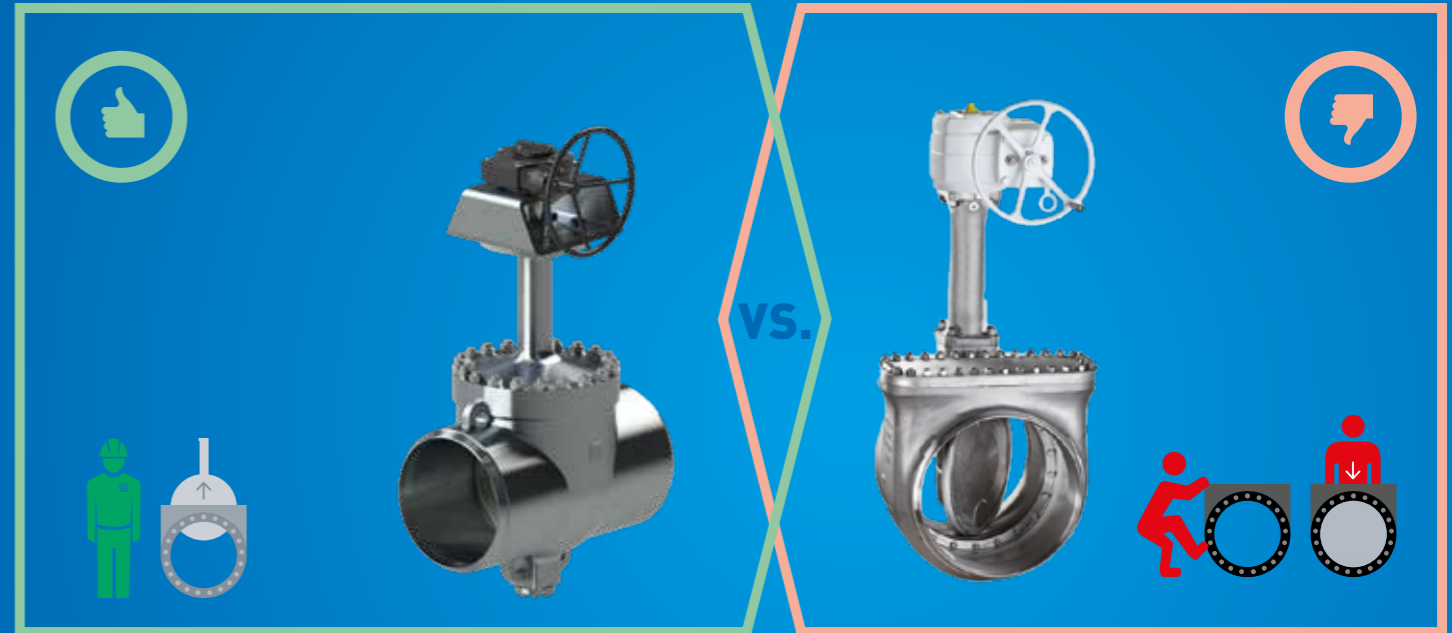

- The unit consisting of shaft and disc is pulled out
- Safe maintenance outside the built-in body
- No residual risks for the service personnel
- Unlimited accessibility in all nominal widths

- The unit consisting of shaft and disc remains in the housing
- Maintenance within the built-in body
- Additional safety measures for the service personnel required
- Accessibility with small nominal widths made difficult

SURPASSED!

ENDURANCE TEST WITHOUT LEAKAGE REFERENCE PROJECT LNG TERMINAL

At LNG terminals, the imported liquid natural gas at a temperature of $-165\text{ }^{\circ}\text{C}$ is unloaded at special docking fixtures by gas tankers and stored in large LNG storage tanks. Prior to delivery to the supply network, the liquefied gas is then uniformly heated and thereby gasified again.



Max. allowable internal leakage acc. to BS6364 for DN 500 = 3000 ml/min.

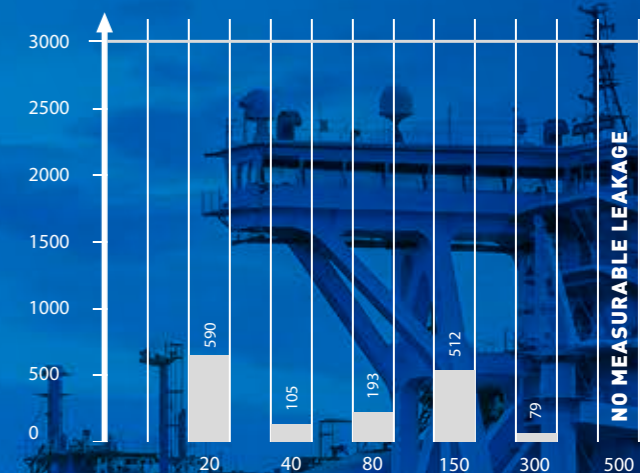

Measured leakage in ml/minute at $-196\text{ }^{\circ}\text{C}$ with helium after each of the indicated cycles.

The müller quadax gmbh has been awarded a contract for a large-scale order for Top Entry premium valves as replacement for Side Entry premium valves in an existing LNG system and for an extension with a new LNG terminal. Along with the LNG tanker loading ramps, this terminal located in Europe also comprises 3 loading ramps for trucks and a special jetty for small (bunker) ships. During storage and transport, natural gas could enter the atmosphere especially at critical components such as measuring devices and process valves. Apart from the negative effects on the environment, these fugitive

emissions could also affect the safety. The operating company of this LNG terminal has demanded an individual performance test for the approval of cryogenic part-turn valves which shall be installed in their terminals and storage tanks. For this purpose, the cryogenic test according to BS 6364 was combined with an endurance test according to EN 12567. An additional requirement was to pass an endurance test, where after 500 mechanical switching operations at $-196\text{ }^{\circ}\text{C}$, the internal and external leakage was measured after particular cycles. The guide value with regard to the

seat leakage is less than 3,000 ml/min for a valve of DN 500 on the basis of the standard BS 6364 and a maximum permissible fugitive emission of $>1.0-10^{-3}\text{ mbar}_l\text{-s}^{-1}$ at any point in time of the cycles. The testing institute ITIS BV attested that the seat leakage never exceeded the already low value of 590 ml/minute and no leakage at all was detected after 500 cycles! In the process, the fugitive emissions were clearly below the standard and hardly measurable.

LIGHTER AND MORE COMPACT

ADVANTAGES OF THE TOP ENTRY VS. BALL VALVE AND GATE VALVE

The QUADAX® PREMIUM VALVE TOP ENTRY is far lighter and more compact than a ball valve leading to a lower weight and thus facilitating installation in pipelines.

COMPARED WITH OTHER DESIGN PRINCIPLES AND OTHER VALVE TYPES, THE QUADAX® PREMIUM VALVE PROVIDES THE FOLLOWING ADVANTAGES:

- No wear on seat and seal
- Maintenance-free, longer service life
- Homogenous shrinking and expanding of materials, also with high ΔT
- 100% tight, also with high temperature fluctuations
- **Less material, lower weight**
- Lower torques -> more compact actuators
- Better controllability

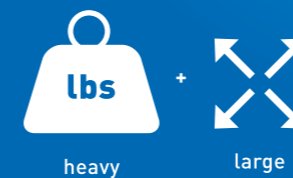

TOP CHOICE!
QUADAX® PREMIUM VALVE
TOP ENTRY

FURTHER SUITABLE PRODUCTS

- QUADAX® 01 DOUBLE FLANGE TYPE
- QUADAX® 02 LUG TYPE
- QUADAX® 03 GATE VALVE REPLACEMENT
- QUADAX® 04 BUTTWELD TYPE
- QUADAX® 05 TOP ENTRY

MADE FOR THE EXTREME

FURTHER PRODUCTS



01
QUADAX® -
DOUBLE FLANGE

Butterfly valve: 4-offset
Pressure range: PN 0-160 bar
Nominal diameter: DN 50-1800 mm
Connection: flange



02
QUADAX® -
LUG TYPE

Butterfly valve: 4-offset
Pressure range: PN 0-63 bar
Nominal diameter: DN 50-1800 mm
Connection: flange



03
QUADAX® -
GATE VALVE
REPLACEMENT

Butterfly valve: 4-offset
Pressure range: PN 0-160 bar
Nominal diameter: DN 80-1800 mm
Connection: flange



04
QUADAX® -
BUTTWELD

Butterfly valve: 4-offset
Pressure range: PN 0-160 bar
Nominal diameter: DN 80-1800 mm
Connection: welding ends

ZERO EMISSIONS

MADE FOR THE EXTREME

YOUR CONTACT PERSON

müller quadax gmbh

Allmand 3
74670 Forchtenberg
Germany
T.: +49 79 47 / 943 43-0
F.: +49 79 47 / 943 43-29

info@quadax.de

www.quadax.de

QUADAX[®]
PREMIUM VALVE
TOP ENTRY
ONLINE



FURTHER PRODUCTS

QUADAX[®] 01 DOUBLE FLANGE TYPE
QUADAX[®] 02 LUG TYPE
QUADAX[®] 03 GATE VALVE REPLACEMENT VERSION
QUADAX[®] 04 BUTTWELD TYPE
QUADAX[®] 05 TOP ENTRY

