

MADE FOR THE **EXTREME** FIELDS OF APPLICATION



www.quadax.de



QUADAX® MADE FOR THE EXTREME



Content

Company profile	04 - 05
QUADAX® PRODUCTION	06 - 09
Highlights	10 - 11
Construction	12 - 13
Applications	14 - 43
References / Products	44 - 45
Quality	46

THE müller co-ax® group

A FAMILY OWNED COMPANY



THE müller quadax gmbh – A COMPANY OF THE MÜLLER-CO-AX® GROUP

Over 60 years of müller co-ax®. A company that has grown from the humblest of beginnings to become a highly reputed valve technology enterprise within the industry. We are synonymous for innovation and individuality, for confidence and quality and for experience and reliability in valve technology. This has been the case since the beginning of our dynamic development and it will continue to stay that way.

More than 60 years of experience does, however, also bring responsibility with it: for our company, for what we have achieved with our employees and of course for our customers.

MADE IN GERMANY

The QUADAX® 4-offset premium valves are produced on modern, fully equipped 5-axis machining centres – 100% in Germany.

This ensures that we can always achieve and secure the highest quality standards. QUADAX® is therefore the perfect solution for demanding applications with high safety requirements.

FAMILY OWNED COMPANY

For our customers, we combine the values and flexibility of a family-owned company with a long-term perspective and the professionalism of a global player. These are just three of the reasons to work with us.

We look forward to hearing from you!

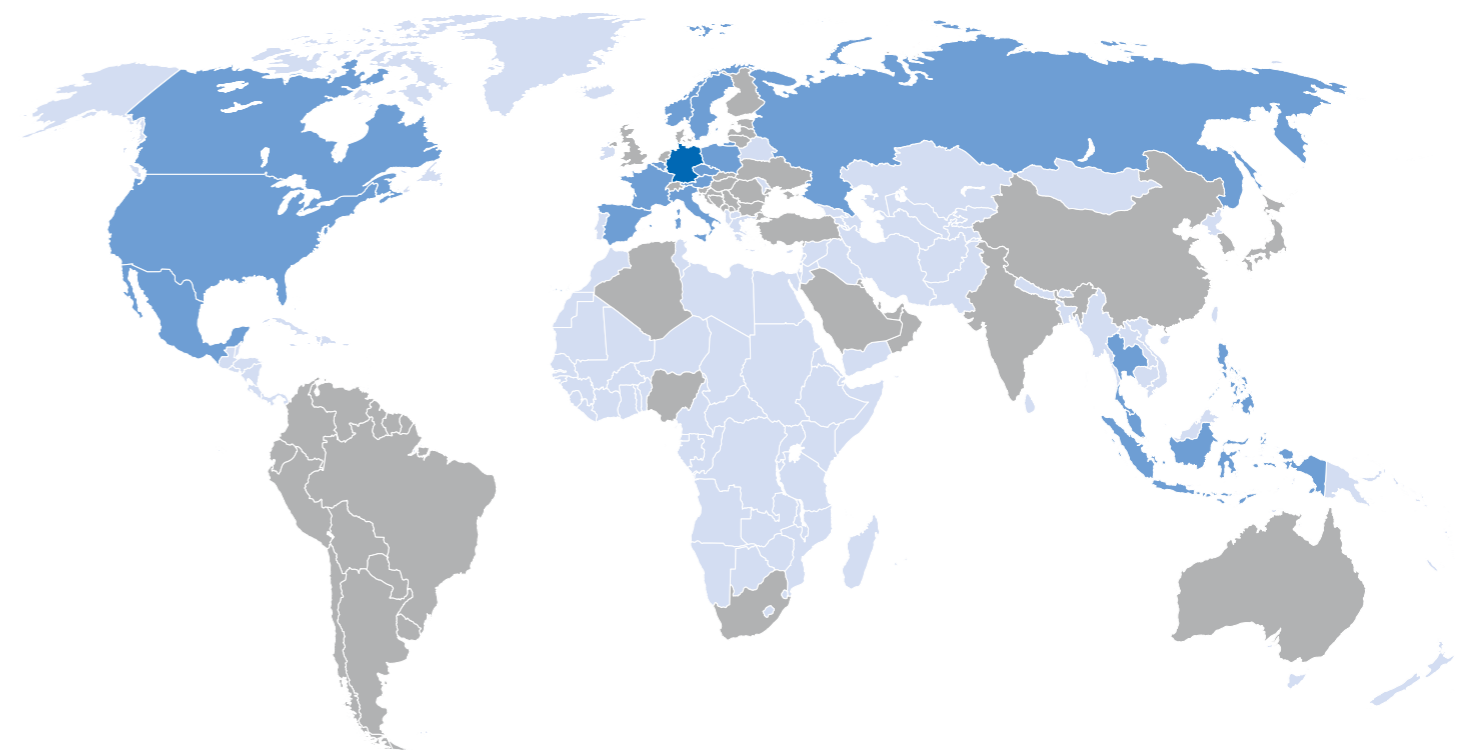

- Sales, Service & Production
- Sales & Service
- Sales

In our production, quality, expertise and experience all come together – **Made in Germany**. Our innovative premium valves are produced on modern, fully equipped 5-axis machining centres. Our manufacturing facilities cover an area of approximately 10,000 square metres with production, assembly and storage. We also have 50 square metres of state-of-the-art testing facilities. Every single work step, from the technical drawing to the final inspection before delivering to the customer, is subject to procedure defined in precision. This ensures that we can always achieve our own high quality standards.

Only the best equipment can provide the basis for products that set standards!



HIGH VERTICAL INTEGRATION - 100% MADE IN GERMANY

- 1.** High quality production on modern 5-axis machining centres
- 2.** Assembly made by qualified employees
- 3.** All valves are 100% tested
- 4.** Highest flexibility thanks to our own paint shop

HIGHLY ACCURATE ASSEMBLY PROCESS

Assembly by our
qualified workforce

QUALITY IS IMPORTANT TO US

Quality is part of our philosophy, which is not only shared by every single employee, but rather is lived. Our experienced and trained staff always ensures that the highest standards of quality are met and highest reliability can be achieved. These requirements are dictated by the extreme applications in which our premium valves are successfully installed.

Our customers can rely on receiving a product that is outstanding and makes no compromises regarding functionality, durability and resistance. We deliver solutions that exceed expectations: Thus only products that have been subjected to a 100% quality inspection and have successfully passed this test leave our factory. We offer quality and competence to our customers. This is proven not only by the high satisfaction of our customers, but also by comprehensive certificates.

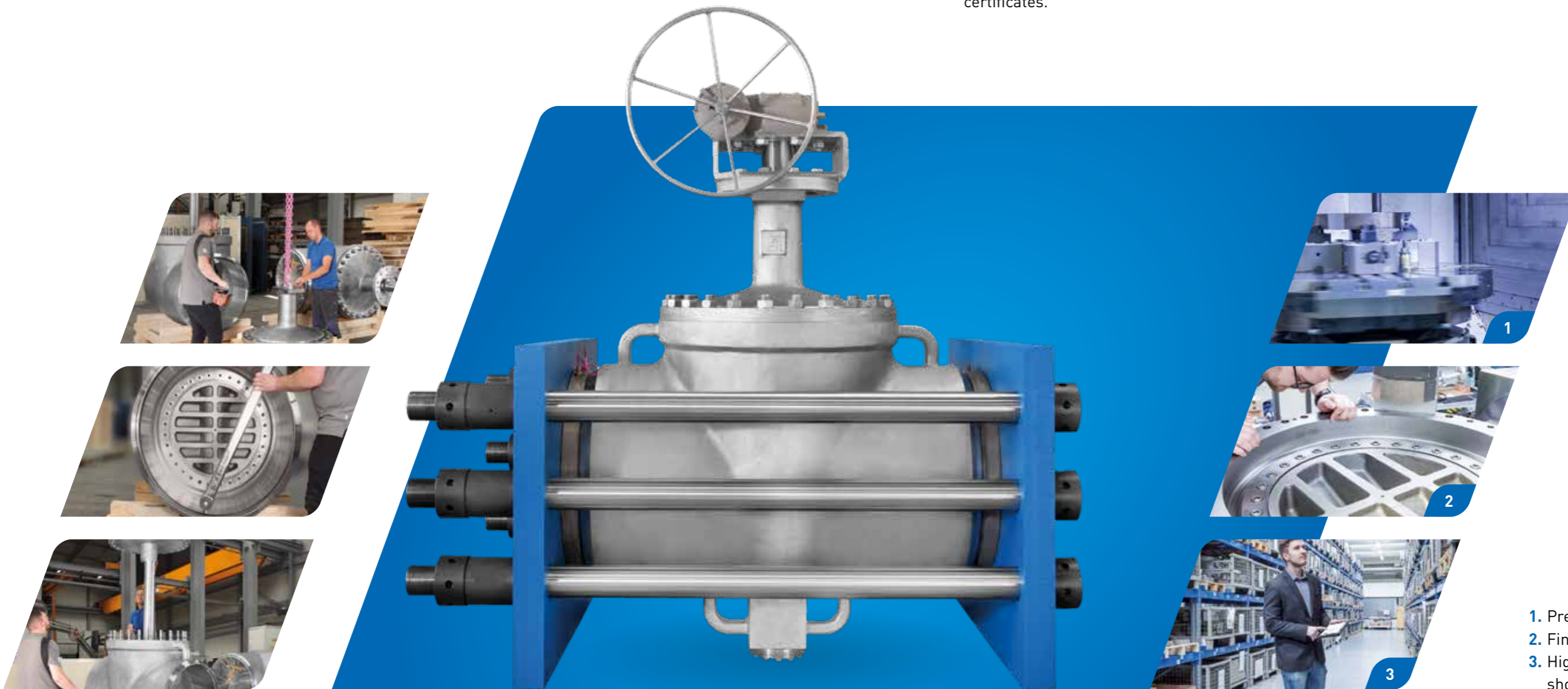

1. Precision work
2. Final quality check
3. High inventory for short deliveries

QUADAX®

HIGHLIGHTS

TEMPERATURE RANGE

from -270°C to +800°C
from -454°F to +1472°F

TIGHT IN BOTH DIRECTIONS

– up to full pressure

FLOATING DISC DESIGN

Highest tightness even in high Δt

NO MOVEMENT

No movement between disc and seal –
absolute tightness between seal and disc

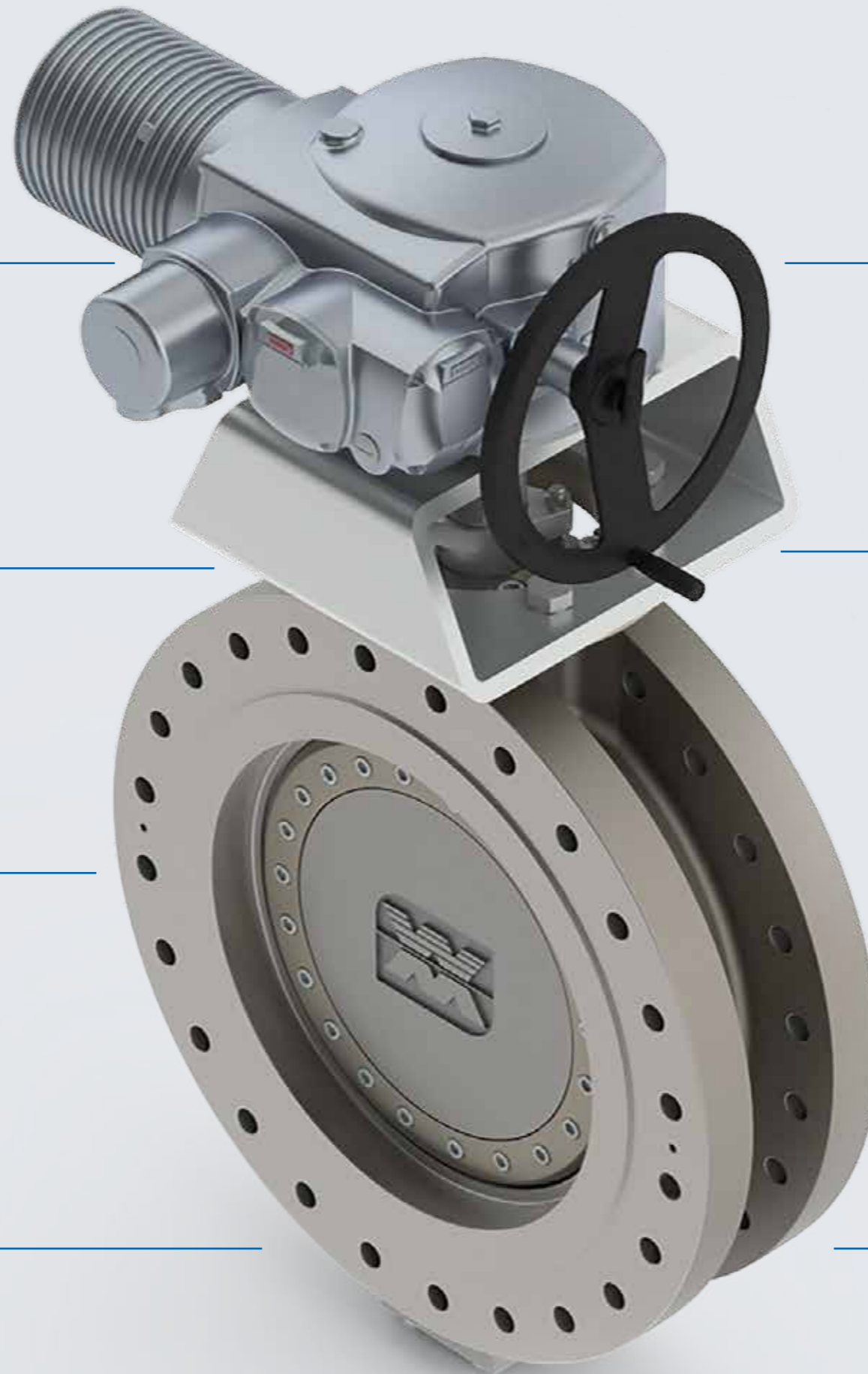

ZERO LEAKAGES

also in cryogenic applications

DN 1800 (72") AND 160 BAR (CLASS 1500, 2320 PSI)

Available up to DN 1800 mm and above / Available up
to 160 bar and above

METAL SEALS

All metal seals possible

MINIMISED DEAD-LEG AREA

Dead-leg area minimised thanks to 4-offset design,
higher Kv/Cv value and less accumulation of dirt

DESIGN PRINCIPLE

In contrast to the elliptical seal geometry of conventional triple offset valves, the QUADAX® features a completely circular seal geometry. Thanks to this unique 4-offset construction the QUADAX® valves offer 100% tightness

even under the most extreme pressure and temperature requirements.

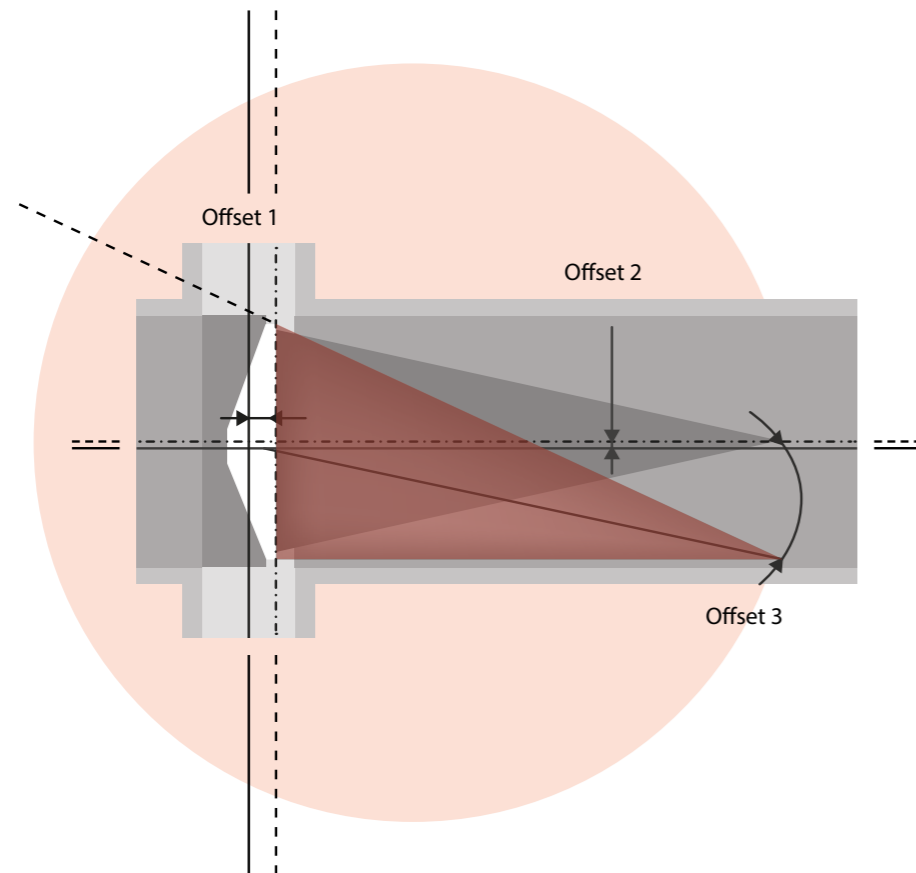

CENTRIC BUTTERFLY VALVE

The turning point is at the centre of the seat and at the centre of the pipe.

→ Only elastomer seals are possible.

SINGLE OFFSET BUTTERFLY VALVE

The turning point of the disc is offset along the direction of the pipe.

→ 100 % friction between seat and seal

→ Increased torque and wear

DOUBLE OFFSET BUTTERFLY VALVE

The turning point of the disc is also offset from the centre of the pipe towards the outer edge.

→ Approx. 30 % friction between seat and seal

TRIPLE OFFSET BUTTERFLY VALVE

The seat has a conical shape. The tip of the cone is offset from the centre of the pipe towards the outer edge. A circular cone results in an elliptical narrow seat in the valve body.

→ Approx. 2-5 % friction between seat and seal

COMPARISON

4- OFFSET PREMIUM VALVE

On the 4-offset premium valve, the output cone used is elliptical.

The section under a particular angle results in a circular and therefore larger sealing area.

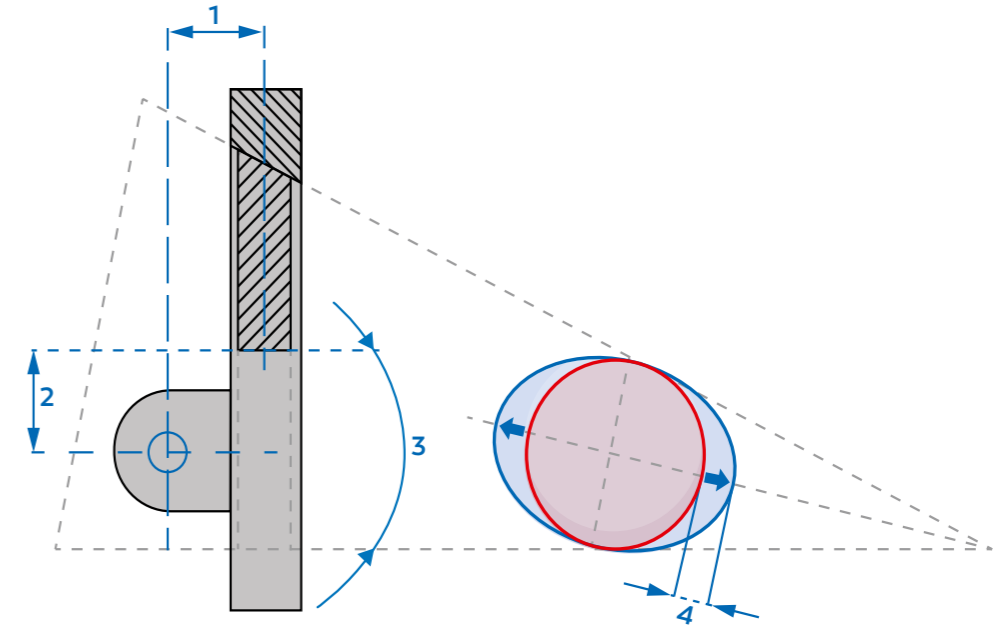

4-Offset QUADAX® PREMIUM VALVES

The 4-offset premium valve offers a completely round seat and sealing geometry

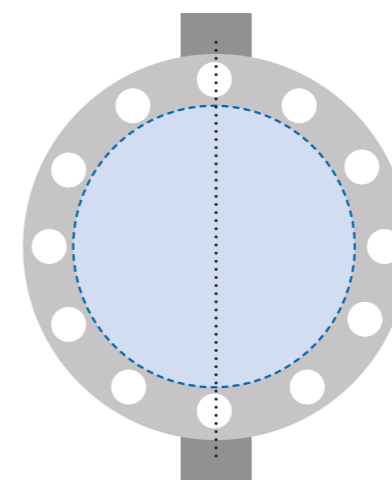

Conventional triple Offset Butterfly Valves

A conventional triple offset valve functions with an elliptical seat and sealing geometry

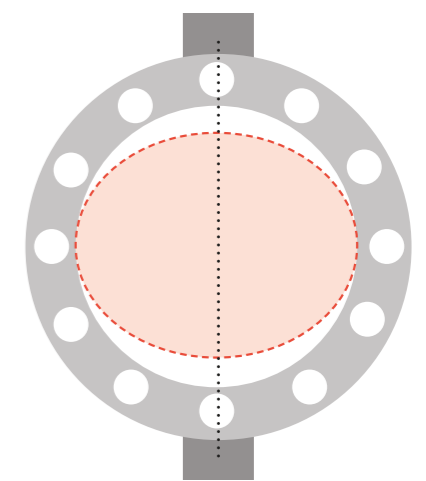

VS



- Friction-free
- Higher KV/CV values
- Highest tightness/No leaks (even in the most extreme conditions)
- Lower torques



- Wear due to friction
- Few leaks
- Maintenance-prone

With the unique design, the 4-offset design and a brand new manufacturing technology, QUADAX® meets the highest sealing requirements even in extreme pressure and temperature ranges.

This makes QUADAX® premium valves outstandingly suitable for the oil and gas industry, the petrochemical industry, cryogenics, refineries, LNG + LPG and many other applications.

With more than 20,000 valve installations worldwide, QUADAX® has fully proven its technology. Even for the most demanding applications, i.e. extreme pressure or temperature ranges.

If you require further information, we will be happy to provide you with our global reference list or with specific references.



LNG- & LPG TERMINALS

In LNG/LPG terminals, liquid gas is stored at cryogenic temperatures in insulated storage tanks until transport or until regasification. The QUADAX® premium valve has already proven itself several times in both processes thanks to its unique technology. We guarantee bubble-free tightness down to $-196\text{ }^{\circ}\text{C}$. Safety is assured thanks to ISO 10497, API 607 and BS 6755 and thus flammable media and high pressures are handled safely. In addition, QUADAX® Top-Entry premium valves for shut-off and control meet the requirements of EN 1473-2016 specifications for valves in their entirety. They are specifically designed for LNG applications, where control and maintenance work can be carried out safely and simply in the installed position without further risks for the maintenance personnel.

SUITABLE PRODUCTS

- QUADAX® 04 BUTTWELD
- QUADAX® 05 TOP ENTRY



THERMOSOLAR SYSTEMS

Thermosolar systems are operated in solar thermal power plants, which use the heat of the sun as the primary energy source, either by absorption of its radiation or by using warm air. The heat transfer medium is either HTF (Heat Transfer Fluid) or molten salt. Temperatures of up to +500°C can be reached. This heat is then used either as industrial process heat or used for steam generation. The water vapour is then used to feed a steam turbine like in a steam power plant. The high tightness requirements at high temperatures and the properties of the carrier medium require special sealing materials. The QUADAX® premium valves have well proven themselves both in applications of HTF or molten salt at +500°C as well as in steam power plants.

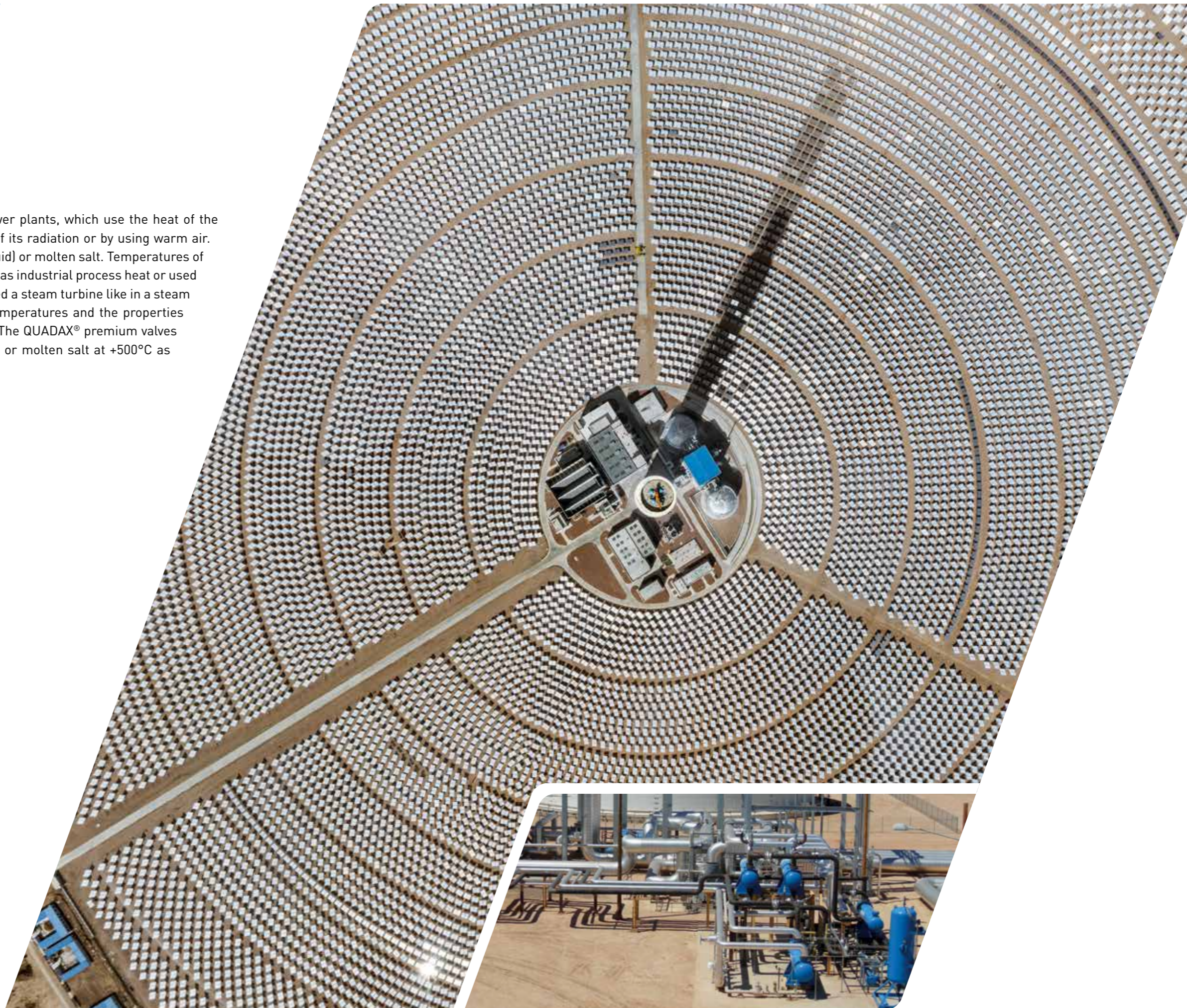

SUITABLE PRODUCTS

- QUADAX® 01 DOUBLE FLANGE
- QUADAX® 02 LUG TYPE
- QUADAX® 04 BUTTWELD

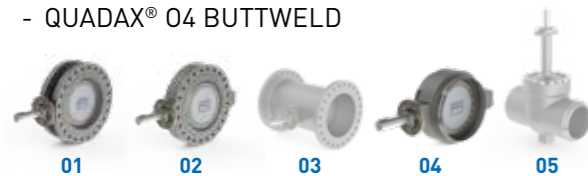

INDUSTRIAL GASES

Industrial gases play an important role in many industrial production plants. Due to their specific properties and their use, many processes will become more efficient, safer and more economical. Industrial gases and gas mixtures must comply to international standards which define the degrees of purity. Whether the valves are used in air decomposers or for the control of liquid gases in tank installations or for the handling of gaseous gases in gas mixers, QUADAX® premium valves reliably meet the high requirements. Our customers have been relying on our valves for years also in pure oxygen applications. The Shaft seals of QUADAX® valves also meet the strict requirements of the German standard "Technical Instructions on Air Quality Control", commonly referred to as the «TA Luft» / ISO 15848-1.

SUITABLE PRODUCTS

- QUADAX® 01 DOUBLE FLANGE
- QUADAX® 02 LUG TYPE
- QUADAX® 04 BUTTWELD

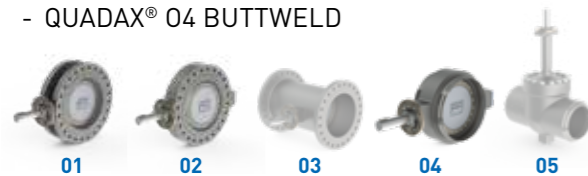

DISTRICT HEATING SYSTEMS

In thermal power plants, the combustion of fossil fuels or Biomass water is converted into hot steam at up to +560° C. With this energy a steam turbine is driven which is coupled to a power generator. With the exhaust steam from the main turbine a so-called backpressure turbine is fed which is installed in a heat and power plant for district heating supply. Depending on the process, the temperature can still exceed +300° C with pressure ratios of up to 100 bar. In a downstream condenser, the liquid decompressed steam is then cooled down to a range of approx. +70°C to +140°C depending on the heat demand before the warm water is delivered to industry or households via a district heating network. QUADAX® valves guarantee the plant operators reliability, efficiency and longevity at full capacity and bubble tightness.

SUITABLE PRODUCTS

- QUADAX® 01 DOUBLE FLANGE
- QUADAX® 02 LUG TYPE
- QUADAX® 03 GATE VALVE REPLACEMENT
- QUADAX® 04 BUTTWELD

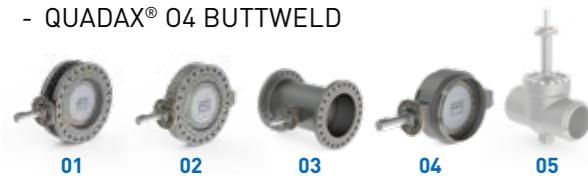

POWER GENERATION

POWER STATIONS

High pressures and temperatures often occur during power generation. For such demanding operating conditions, the QUADAX® premium valve is designed to be used in the most demanding applications. In the field of nuclear energy, our products meet the highest safety requirements. QUADAX® valves have been reliable for years in primary and secondary cooling circuits in the field. But not only in nuclear energy, also in the processing of fossil fuels e.g. in gas turbines or power plants with combined heat and power generation and in the conversion of regenerative energy sources, QUADAX® 4-offset premium valves are applied to the full satisfaction of the enduser.

SUITABLE PRODUCTS

- QUADAX® 01 DOUBLE FLANGE
- QUADAX® 03 GATE VALVE REPLACEMENT
- QUADAX® 04 BUTTWELD



HYDROGEN

PRODUCTION & STORAGE

For the production of nitrogen fertiliser or for the cracking of hydrocarbons in petroleum refineries hydrogen is used. Hydrogen is also applied in chemical processes for the production of synthetic fuels derived from gas, coal or biomass. In addition, hydrogen fuel cells as environmentally friendly energy converters are becoming increasingly important in the field of electromobility. Steam reforming is currently the most important large-scale industrial process for production of hydrogen from carbonaceous energy sources where natural gas is currently the most important raw material. In steam generation, QUADAX® premium valves are successfully applied at temperatures from +250°C to +300°C and pressures from 40 - 100 bar. To ensure that industrial production capacity is better adjusted to the fluctuating demand of hydrogen, energy storage systems are necessary. The gaseous hydrogen is cooled down to -253° C, compressed and thus liquefied in liquid gas storage tank. Both for the transport in gaseous as well as in the liquid state, the QUADAX® premium valves prove their full functionality.

SUITABLE PRODUCTS

- QUADAX® 01 DOUBLE FLANGE
- QUADAX® 02 LUG TYPE
- QUADAX® 03 GATE VALVE REPLACEMENT
- QUADAX® 04 BUTTWELD
- QUADAX® 05 TOP ENTRY



OIL & GAS UPSTREAM

EXTRACTION, TRANSPORT, STORAGE

In the field of oil and gas production, transport and storage, high requirements are made on the safety of the valves, since in all processes the danger of fires are latently high. Occupational safety and environmental protection are the top priorities. Our valves are in accordance with DIN EN ISO 10497, 2004 and API 607, 6th edition for all pressure levels, firesafe tested and certified in both flow directions. But QUADAX® premium valves are also used in secondary and tertiary conveying for the injection of natural gas, hot steam or other fluids under high pressure to increase the production rate of the crude oil reservoir or to increase the viscosity of the crude oil in order to be able to separate the oil from the solids more easily. In offshore oil production, in addition to the high safety requirements QUADAX® premium valves with high-quality corrosion-free materials are working successfully even in nasty environmental conditions.

SUITABLE PRODUCTS

- QUADAX® 01 DOUBLE FLANGE
- QUADAX® 02 LUG TYPE
- QUADAX® 03 GATE VALVE REPLACEMENT
- QUADAX® 04 BUTTWELD



OIL & GAS DOWNSTREAM

PETROCHEMICAL INDUSTRY

Both in distillation processes, steam and condensate systems and flare gas systems demanding operating conditions such as high temperatures combined with high pressures have to be under control. In addition, safety by absolute tightness and the firesafe function in both flow directions is at the topmost point when handling highly flammable or explosive gases and liquids. Our valves are according to DIN EN ISO 10497, 2004 and API 607, 6th edition tested and certified for all pressure levels. Also the safety-relevant precautions in explosive zones according to ATEX are implemented depending on the requirements and certified accordingly. In addition, the petrochemical processes often contain aggressive acids like by-products for the production of plastics such as ethylene and propylene. The QUADAX® premium valves meet the necessary standards and requirements for the valves regarding design, ANSI - connection dimensions, the materials used as well as the leakage tests. The reliability of our valves and fittings contributes decisively to the fact that fires, unscheduled delays or shutdowns are avoided and thus the safety and production efficiency can be increased. Fire safety certifications according to API / ATEX / German standard "Technical Instructions on Air Quality Control", commonly referred to as the «TA Luft» / ISO 15848-1 and other tests can be provided.

SUITABLE PRODUCTS

- QUADAX® 01 DOUBLE FLANGE
- QUADAX® 02 LUG TYPE
- QUADAX® 03 GATE VALVE REPLACEMENT
- QUADAX® 04 BUTTWELD



LOW TEMPERATURES

CRYOGENIC APPLICATIONS

Cryogenic liquids are produced by air decomposition plants by liquefying the corresponding gases which are filled either into stationary tanks or into special transport containers and then taken to the appropriate application. The most commonly used liquid cryogenics are nitrogen, oxygen, hydrogen, argon and helium. Cryogenic temperatures of up to -270°C are not uncommon. QUADAX® premium valves are worldwide successfully installed in air decomposition plants and in other freezing processes where high temperature differences occur. The round sealing geometry allows a uniform wall thickness of the sealing seat thus ensuring that a linear expansion/shrinkage can take place during temperature fluctuations. This unique design provides the best tightness.

SUITABLE PRODUCTS

- QUADAX® 01 DOUBLE FLANGE
- QUADAX® 02 LUG TYPE
- QUADAX® 03 GATE VALVE REPLACEMENT
- QUADAX® 04 BUTTWELD
- QUADAX® 05 TOP ENTRY



OXYGEN

APPLICATIONS

Technical oxygen is used, for example, in the chemical industry, steel industry, environmental technology or applied in mining and for fuel gas mixtures. In contact with airborne dispersed fine solid particles or with mineral lubricants there is a risk of explosion, as they are extremely easy to ignite and burn with explosive intensity as higher the concentration and pressure of the oxygen is. QUADAX® valves are specially cleaned for this purpose and oxygen-compatible greases are applied during the assembly. The test report of the Federal Institute for Materials Testing certifies that our premium valves meet the requirements of the rules M034 for oxygen, version 12/2005, of the professional association of the chemical industry for the use of gaseous oxygen at operating pressures up to 300 bar and operating temperatures up to 550 C°. Thanks to the frictionless closing of the valve, the high tightness and its Fire-Safe construction in both directions the QUADAX® premium valve contributes to your safety, also with regard to burnout safety for exposure to oxygen shock pressure.

SUITABLE PRODUCTS

- QUADAX® 01 DOUBLE FLANGE
- QUADAX® 02 LUG TYPE
- QUADAX® 04 BUTTWELD
- QUADAX® 05 TOP ENTRY



INDUSTRIAL COMPRESSORS

Industrial compressor systems compress different gases and gas mixtures, which are used in numerous industrial processes. Such complex systems compress, high-purity or highly flammable technical gases such as for example argon, oxygen, hydrogen, helium but also ethylene, fluorine, hydrogen sulphide or chlorine. The compressed gases are filled into special storage containers or directly fed into the intended process. For safety reasons the installed valves have to function safely without leakage even under heating and high pressures. Especially when controlling high purity and highly flammable gases, the abrasion-free design of the 4-offset QUADAX® premium valve pays off. This is one of the reasons why well-known international manufacturers of industrial compressor systems are using our valves to their complete satisfaction.

SUITABLE PRODUCTS

- QUADAX® 01 DOUBLE FLANGE
- QUADAX® 02 LUG TYPE



AEROSPACE

ROCKET LAUNCHING PAD

In order to meet the constantly growing demand for the economic transportation of medium and heavier satellites for civilian purposes, the space stations for orbital missiles continuously expanded. On a spaceport there is a high technological infrastructure on which spacecrafts are launched. The fuel combination of hydrogen and oxygen along with other chemical fuels are mostly used in liquid fuel rockets today. Some storable liquid propellants are very caustic or corrosive, which makes the use of special materials necessary. Both in the production and storage of liquid rocket propellants as well as during the refuelling of the rocket with such cryogenic fuel components having a temperature of partially colder than -220°C , reliability and thus safety is the top priority. Even the smallest leakage can have disastrous consequences. That is why our demanding customers appreciate the 4-offset design, the high quality and the know-how of müller quadax.

SUITABLE PRODUCTS

- QUADAX® 01 DOUBLE FLANGE
- QUADAX® 02 LUG TYPE
- QUADAX® 04 BUTTWELD
- QUADAX® 05 TOP ENTRY



CHEMICAL INDUSTRY

The use of the QUADAX® premium valve in the chemical industry is as varied as the product itself. Many of our end customers in this industry have successfully installed our premium valves in steam applications. Steam is an efficient heat carrier and relatively easy to control. It is often used for the transport of energy from the central steam generation to any number of consumers in a chemical plant to heat water, gases or for a specific process application. Because of the high pressure and temperature range depending on the sealing versions, our premium valves can be used in superheated steam as well as in saturated steam. In addition, our premium valves perform reliably their function in the control of technical gases and liquefied gas where low temperatures even below -220°C occur. The shaft seal of the QUADAX® premium valves meet the strict requirements of fire safety certifications according to API / ATEX / "Technical Instructions on Air Quality Control", commonly referred to as the «TA Luft» / ISO 15848-1.

SUITABLE PRODUCTS

- QUADAX® 01 DOUBLE FLANGE
- QUADAX® 02 LUG TYPE
- QUADAX® 03 GATE VALVE REPLACEMENT
- QUADAX® 04 BUTTWELD
- QUADAX® 05 TOP ENTRY



SHIPBUILDING

FUEL SUPPLY SYSTEMS

In modern shipbuilding, LNG propulsion technology is gaining ground due to stricter regulations regarding emissions of nitrogen oxides and sulphur dioxide. Therefore, this new technology is becoming increasingly important for both freighters, tankers as well as for passenger ships. Due to the low emissions of LNG this fuel is much cleaner than diesel oil and even more than heavy fuel oil. The natural gas is stored in liquid form in special ship tanks and will be transformed back into gas in complex reliquefaction plants before supplying the combustion chambers of the ship's engine, or the gas turbine. QUADAX® premium valves are certified to DNV-GL and applied in LNG propulsion technology both in the low and high pressure range and contribute to a reliable control of the fuel supply. These include the ship's bunker systems, tank, cold box (gas processing) and the Fuel Gas Supply System (FGSS) to the engine or gas turbine. Full tightness with temperatures from -196°C to +100°C are required. In addition, gearboxes and actuators are specially coated for seawater applications with corrosion protection class C5-M.



SUITABLE PRODUCTS

- QUADAX® 04 BUTTWELD
- QUADAX® 05 TOP ENTRY



OUR REFERENCES

In our production, quality, expertise and experience all come together – Made in Germany. Our innovative premium valves are produced on modern, fully equipped 5-axis machining centres. Our manufacturing facilities cover an area of approximately 10,000 square metres with production, assembly and storage. We also dispose comprehensive state-of-the-art testing facilities. Every single work step, from the technical drawing to the final inspection before delivering to the customer, is subject to procedure defined in precision. This ensures that we can always achieve our own high quality standards. Only the best equipment can provide the basis for products that set standards! Therefore international customers trust to the outstanding quality of QUADAX® premium valves.



QUADAX® PRODUCTS



01
QUADAX® –
DOUBLE
FLANGE

Premium valve: 4-offset
Pressure range: PN 0-160 bar
Nominal diameter: DN 50-1800 mm
Connection: flange

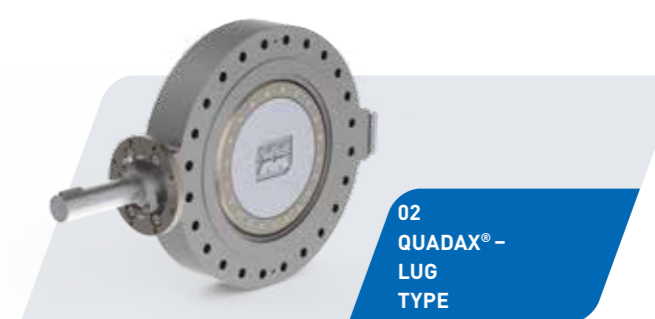

02
QUADAX® –
LUG
TYPE

Premium valve: 4-offset
Pressure range: PN 0-63 bar
Nominal diameter: DN 50-1800 mm
Connection: flange



03
QUADAX® –
GATE VALVE
REPLACEMENT

Premium valve: 4-offset
Pressure range: PN 0-160 bar
Nominal diameter: DN 80-1800 mm
Connection: flange



04
QUADAX® –
BUTT WELD

Premium valve: 4-offset
Pressure range: PN 0-160 bar
Nominal diameter: DN 80-1800 mm
Connection: welding ends



05
QUADAX® –
TOP
ENTRY

Premium valve: 4-offset
Pressure range: PN 0-160 bar
Nominal diameter: DN 100-1000 mm
Connection: welding ends

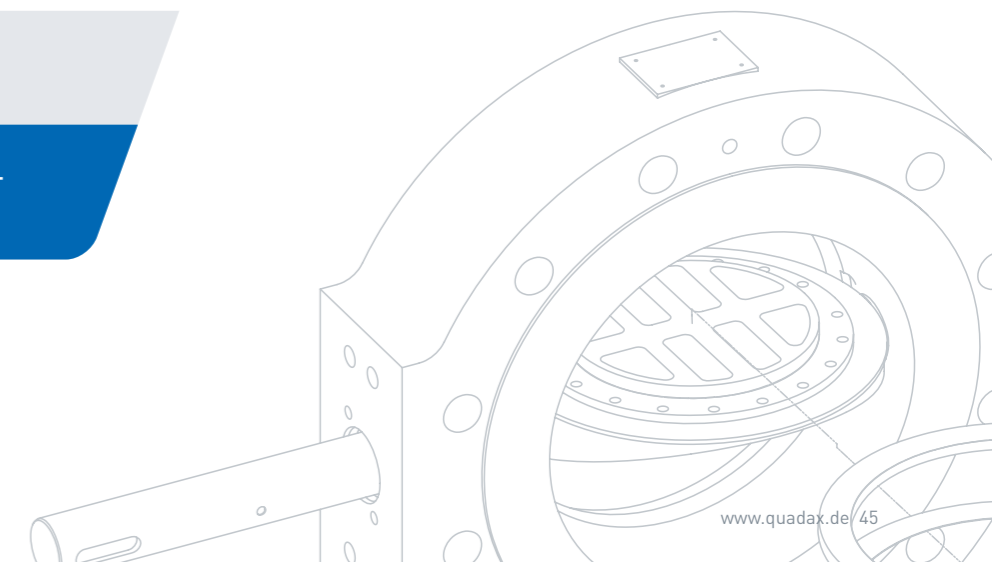

HIGH STANDARDS FOR HIGH-QUALITY FITTINGS

CERTIFICATIONS / STANDARDS



- TÜV SÜD ISO 9001:2015
- CE 0036 Certification
- ISO 15848 / TA-Luft
- Fire-Safe acc. ISO 10497, API 607, BS 6755
- BAM Certification
- EAC Certification
- AD 2000 A4, ADW 10 HPO
- ANSI 16.34
- PED 2014/68/EU
- Leakage rate A EN12266 / API 598
- SIL 3
- DNV Type Approval
- BS 6364 / EN 12567-1

... we have more certifications!
If you cannot find a certificate in the list, please ask us
simply by mail (info@quadax.de).



All technical specifications correspond to the state of printing. We reserve the right to make changes. Unfortunately, we cannot completely rule out errors. Please understand that from the information, illustrations, data and descriptions no legal claims can be derived. The texts, photos, technical drawings, descriptions and all other forms of presentation contained in this publication are protected property of müller quadax gmbh. Any further use requires the express consent of quadax gmbh.



YOUR CONTACT

müller quadax gmbh

Allmand 3
74670 Forchtenberg
Germany

T.: +49 79 47 / 943 43-0
F.: +49 79 47 / 943 43-29

info@quadax.de